

I

Name _____

Roll No. _____ Year 20____20____

Exam Seat No. _____

ELECTRICAL GROUP | SEMESTER - VI | DIPLOMA IN ENGINEERING AND TECHNOLOGY

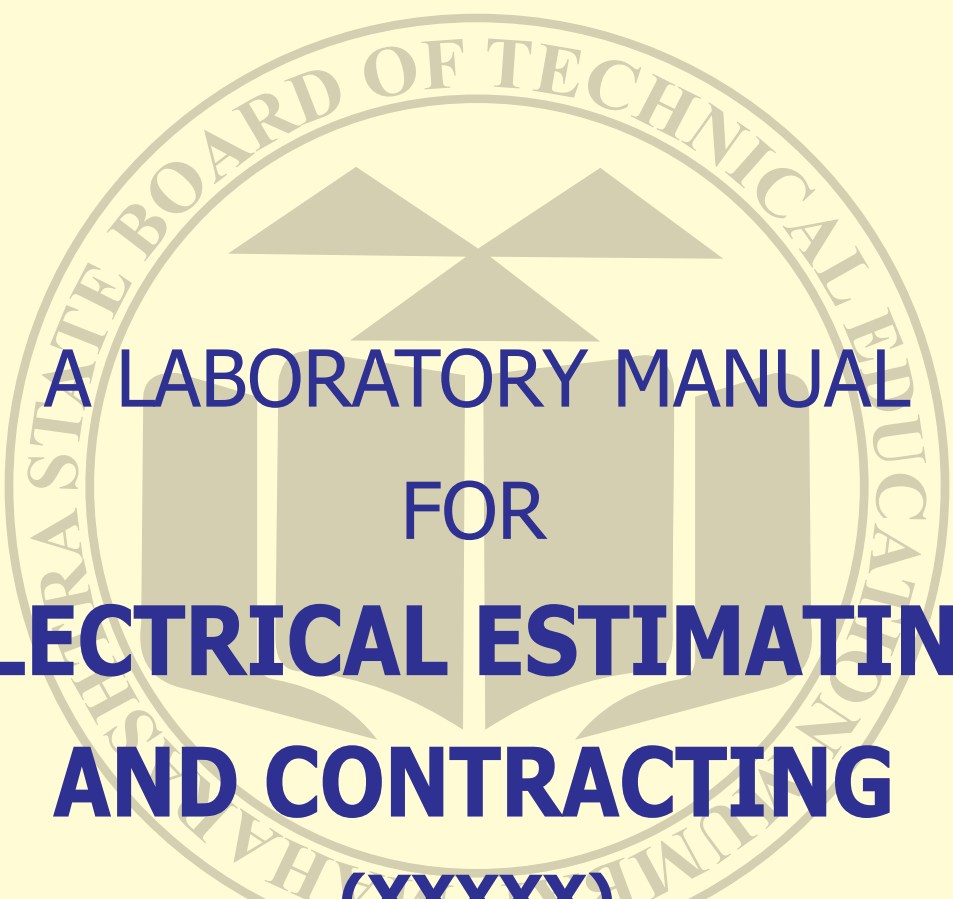

A LABORATORY MANUAL FOR ELECTRICAL ESTIMATING AND CONTRACTING (XXXXXX)

ACTIVITIES UNDER ELECTRICAL ESTIMATION AND CONTRACTING

**DESIGN &
PLANNING**

DRAWING

**ESTIMATION &
COSTING**

**TENDER &
QUOTATION**



MAHARASHTRA STATE BOARD OF TECHNICAL EDUCATION, MUMBAI
(Autonomous) (ISO 9001 : 2015) (ISO / IEC 27001 : 2013)

A Practical Manual for

Electrical Estimating and Contracting

(22627)

Semester – VI

(EE, EP, EU)

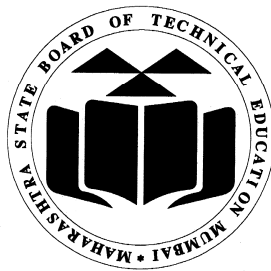

Maharashtra State

Board of Technical Education, Mumbai

(Autonomous) (ISO-9001-2008) (ISO/IEC 27001:2013)



Maharashtra State
Board of Technical Education, Mumbai

(Autonomous) (ISO-9001-2008) (ISO/IEC 27001:2013)

4th Floor, Government Polytechnic Building, 49, Kherwadi,

Bandra (East), Mumbai -400051.

(Printed on November 2019)

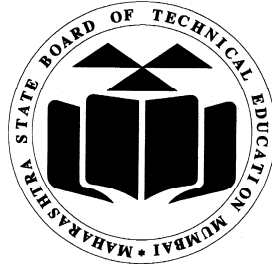

Maharashtra State Board of Technical Education Certificate

This is to certify that Mr./Ms.....Roll
No..... of Sixth Semester of Diploma in
..... of Institute
..... (Code.....)
has attained predefined practical outcomes (PROs) satisfactorily in
course **Electrical Estimating and Contracting (22627)** for the
academic year 20.....to 20..... as prescribed in the curriculum.

Place Enrollment No.....

Date:..... Exam Seat No.

Course Teacher

Head of the Department

Principal

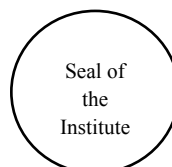

Preface

The primary focus of any engineering laboratory/ field work in the technical education system is to develop the much needed industry relevant competencies and skills. With this in view, MSBTE embarked on this innovative 'I' Scheme curricula for engineering diploma programmes with outcome-based education as the focus and accordingly, relatively large amount of time is allotted for the practical work. This displays the great importance of laboratory work making each teacher; instructor and student to realize that every minute of the laboratory time need to be effectively utilized to develop these outcomes, rather than doing other mundane activities. Therefore, for the successful implementation of this outcome-based curriculum, every practical has been designed to serve as a '*vehicle*' to develop this industry identified competency in every student. The practical skills are difficult to develop through 'chalk and duster' activity in the classroom situation. Accordingly, the 'I' scheme laboratory manual development team designed the practicals to *focus* on the *outcomes*, rather than the traditional old age practice of conducting practicals to 'verify the theory' (which may become a byproduct along the way).

This laboratory manual is designed to help all stakeholders, especially the students, teachers and instructors to develop in the student the pre-determined outcomes. It is expected from each student that at least a day in advance, they have to thoroughly read through the concerned practical procedure that they will do the next day and understand the minimum theoretical background associated with the practical. Every practical in this manual begins by identifying the competency, industry relevant skills, course outcomes and practical outcomes which serve as a key focal point for doing the practical. The students will then become aware about the skills they will achieve through procedure shown there and necessary precautions to be taken, which will help them to apply in solving real-world problems in their professional life.

This manual also provides guidelines to teachers and instructors to effectively facilitate student-centered lab activities through each practical exercise by arranging and managing necessary resources in order that the students follow the procedures and precautions systematically ensuring the achievement of outcomes in the students.

The electrical diploma holder has to work in industry as technical person in middle level management. He has to work as production, maintenance, testing engineer in various industries like power generation, transmission, distribution, traction etc. and has to deal with different electrical measurement. While performing above task he has to measure different electrical and electronic parameters with testing, therefore he/she must require the skills for these measurements and broad idea of different meters and equipments.

Although all care has been taken to check for mistakes in this laboratory manual, yet it is impossible to claim perfection especially as this is the first edition. Any such errors and suggestions for improvement can be brought to our notice and are highly welcome.

Programme Outcomes (POs) to be achieved through Practical of this Course

Following POs and PSO are expected to be achieved through the practicals of the course, Energy Conservation and Audit.

- PO 1. **Basic knowledge:** Apply knowledge of basic mathematics, sciences and basic engineering to solve the broad-based Electrical engineering problems.
- PO 2. **Discipline knowledge:** Apply Electrical engineering knowledge to solve broad-based electrical engineering related problems.
- PO 3. **Experiments and practice:** Plan to perform experiments and practices to use the results to solve broad-based Electrical engineering problems.
- PO 4. **Engineering tools:** Apply relevant Electrical technologies and tools with an understanding of the limitations.
- PO 5. **The engineer and society:** Assess societal, health, safety, legal and cultural issues and the consequent responsibilities relevant to practice in the field of Electrical engineering.
- PO 6. **Environment and sustainability:** Apply Electrical engineering solutions for sustainable development practices in societal and environmental contexts.
- PO 7. **Ethics:** Apply ethical principles for commitment to professional ethics, responsibilities and norms of the practice in the field of Electrical engineering.
- PO 8. **Individual and team work:** Function effectively as a leader and team member in diverse/ multidisciplinary teams.
- PO 9. **Communication:** Communicate effectively in oral and written form
- PO 10. **Life-long learning:** Engage in independent and life-long learning activities in the context of technological changes in the Electrical engineering and allied industry.

Program Specific Outcomes (PSOs)

PSO 1. Electrical Equipment: Maintain various types of rotating and static electrical equipment.

PSO 2. Electric Power Systems: Maintain different types of electric power systems.

List of Industry Relevant Skills

The following industry relevant skills of the competency '**Electrical Estimating and Contracting**' are expected to be developed in the students by undertaking the laboratory/field work in this practical manual.

1. To understand and draw plan of different types of electrical installations.
2. Application of relevant IE rule and safety norms in accordance with type of installation.
3. Prepare estimation and costing for the given electrical installation.
4. Use of standard symbols, clearances and protective system for the given electrical installation.
5. Preparation of tender documents and quotations bills.

Practical Course Outcome matrix

S. No.	Practical Outcome	CO a.	CO b.	CO c.	CO d.	CO e.	CO f.
	Course Outcomes (COs):- a. Interpret various electrical diagrams. b. Prepare estimate of domestic and commercial electrical installations. c. Prepare estimate of industrial electrical installations. d. Prepare estimate of overhead and underground distribution lines. e. Prepare estimate of public lighting installations. f. Prepare quotation, tender and other related documents.						
1.	Draw plan of electrical installation scheme for given 1BHK residential unit using Auto-cad.	√	√				
2.	Draw plan of electrical installation scheme for given small commercial unit using Auto-cad.	√	√				
3.	Draw plan of electrical installation scheme for given small factory / industrial unit using Auto-cad.	√		√			
4.	Draw plan of electrical installation scheme for given HT (11kV) connection using Auto-cad.	√			√		
5.	Draw plan of electrical installation scheme for given LT (415V) line connection using Auto-cad.	√			√		
6.	Draw plan of public lighting installation scheme of given premises using Auto-cad.	√				√	
7.	Prepare tender documents, quotations, and bills for specified work.	√	√	√	√	√	√

Guidelines to Teachers

1. **Teacher need to ensure that a dated log book** for the whole semester, apart from the laboratory manual is maintained by every student which She/he has to **submit for assessment to the teacher** in the next practical session.
2. There will be two sheets of blank pages after every practical for the student to report other matters (if any), which is not mentioned in the printed practicals.
3. For difficult practicals if required, teacher could provide the demonstration of the practical emphasizing of the skills which the student should achieve.
4. Teachers should give opportunity to students for hands-on after the demonstration.
5. Assess the skill achievement of the students and COs of each unit.
6. One or two questions ought to be added in each practical for different batches. For this teacher can maintain various practical related question bank for each course.
7. If some repetitive information like data sheet, use of software tools etc. has to be provided for effective attainment of practical outcomes, they can be incorporated in Appendix.
8. For effective implementation and attainment of practical outcomes, teacher ought to ensure that in the beginning itself of each practical, students must read through the complete write-up of that practical sheet.
9. During practical, ensure that each student gets chance and takes active part in taking observations/ readings and performing practical.
10. Teacher ought to assess the performance of students continuously according to the MSBTE guidelines

Instructions for Students

1. For incidental writing on the day of each practical session every student should maintain a **dated log book** for the whole semester, apart from this laboratory manual which s/he has to **submit for assessment to the teacher** in the next practical session.
2. For effective implementation and attainment of practical outcomes, in the beginning itself of each practical, students need to read through the complete write-up including the practical related questions and assessment scheme of that practical sheet.
3. Student ought to refer the data books, IS codes, Safety norms, Electricity act/rules, technical manuals, etc.
4. Student should not hesitate to ask any difficulties they face during the conduct of practicals.

Content Page

List of Practicals and Progressive Assessment Sheet

S. No	Practical Outcome	Page No.	Date of performance	Date of submission	Assessment marks (25)	Dated sign. of teacher	Remarks (if any)
1	Draw plan of electrical installation scheme for given 1BHK residential unit using Auto-cad.	1					
2	Draw plan of electrical installation scheme for given small commercial unit using Auto-cad.	12					
3	Draw plan of electrical installation scheme for given small factory / industrial unit using Auto-cad.	19					
4	Draw plan of electrical installation scheme for given HT (11kV) connection using Auto-cad.	28					
5	Draw plan of electrical installation scheme for given LT (415V) line connection using Auto-cad.	36					
6	Draw plan of public lighting installation scheme of given premises using Auto-cad.	45					
7	Prepare tender documents, quotations, and bills for specified work.	55					
Total							

Note: To be transferred to relevant Performa of CIAAN-2017

Practical No.1 : Draw plan of electrical installation scheme for given 1BHK residential unit using Auto-cad.

I Practical Significance

Every diploma electrical engineer must have the knowledge of Auto-cad for making the drawing of various electrical installations and identify the symbolic representation of appliances/ equipment, distribution board and their position / location as per IE rules.

Relevant Program Outcomes (POs)

- **Discipline knowledge:** Apply Electrical Engineering knowledge to solve broad based Electrical Engineering related problems.
- **Environment and sustainability:** Apply Electrical engineering solutions for sustainable development practices in societal and environmental contexts.
- **Engineering tools:** Apply relevant Electrical technologies and tools with an understanding of the limitations.
- **The engineer and society:** Assess societal, health, safety, legal and cultural issues and the consequent responsibilities relevant to practice in the field of Electrical engineering.
- **Ethics:** Apply ethical principles for commitment to professional ethics, responsibilities and norms of the practice in the field of electrical engineering.
- **Communication:** Communicate effectively in oral and written form.

II Competency and Skills

The aim of this course is to help the student to attain the following industry identified competency through various teaching learning experiences:

- Plan electrical installations with their cost estimates.

III Relevant Course Outcome(s)

- Interpret various electrical diagrams.
- Prepare estimate of domestic and commercial electrical installations.

IV Practical Outcome

- Draw single line wiring diagram of above residential installation.
- Draw the symbols of installation components/ equipments on the above plan showing their location.
- Draw the installation wiring route diagram for the above plan.

V Minimum Theoretical Background

- Meaning and purpose of symbols used to represent electrical equipment in given electrical installation system.
- Application and need of electrical accessories and protective devices based on type of installation.
- Determining the Size/Rating of distribution board, wires and protective equipment.
- IE rules pertaining to electrical installation.
- Knowledge of Auto-cad.

VI Plan layout/ Wiring diagram /Work Situation

- Paste the plan of 1 BHK residential unit whose electrical plan has to be drawn by using Auto-cad.
- Paste labelled drawing representing location of electrical installation components, sub-distribution board by standard electrical symbol.
- Paste wiring/ conduit route diagram join the equipments with respective distribution board through shortest route.
- Paste single line wiring diagram of 1BHK residential electrical installation.

Important Note: This course is having an individual scope; every students group can work out with some different installations of course with the consideration of valid assumptions.

Note: The staff member has to provide/ suggest, in choosing plan of 1 BHK to a student/ group of students.

- Paste the plan of the provided/ suggested to opt for the 1 BHK residential unit whose electrical plan has to be drawn by using Auto-cad. (The sample plan of 1 BHK given for reference)

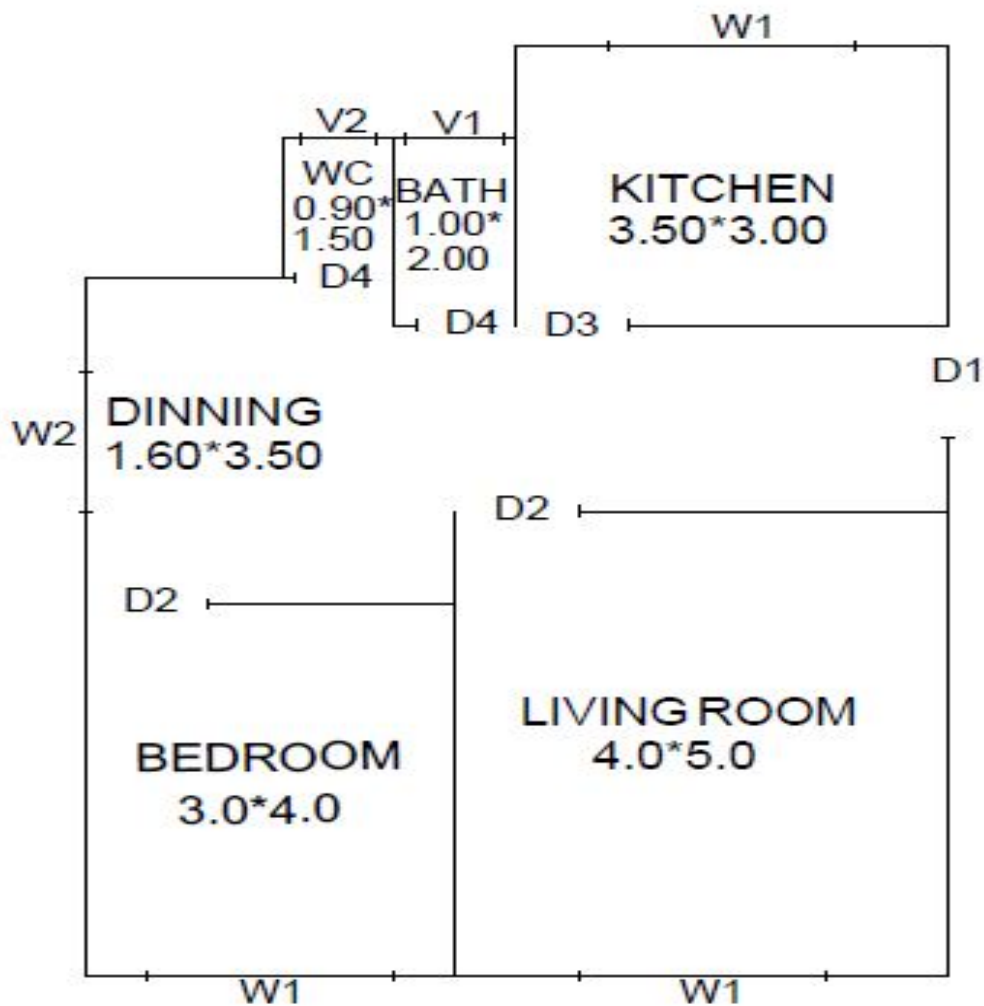

All dimensions are in meters

- D1, D2, D3 and D4: Doors of similar dimensions.
- W1 and W2: Windows of similar dimensions.
- V1, V2: Ventilation openings/ window.

b. Paste labelled drawing representing location of electrical components, sub-distribution board by using standard symbols for the provided/ suggested to opt for the 1 BHK residential unit using Auto-cad.

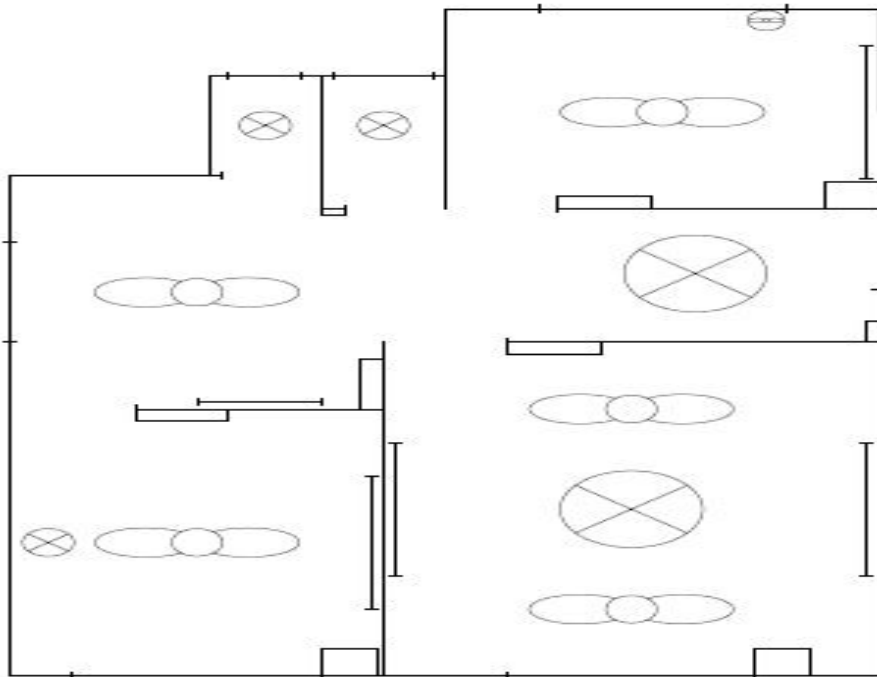

c. Paste wiring/ conduit route layout diagram of the equipment showing their connection to respective distribution board through shortest route for the provided/ suggested to opt for the 1 BHK residential unit using Auto-cad.

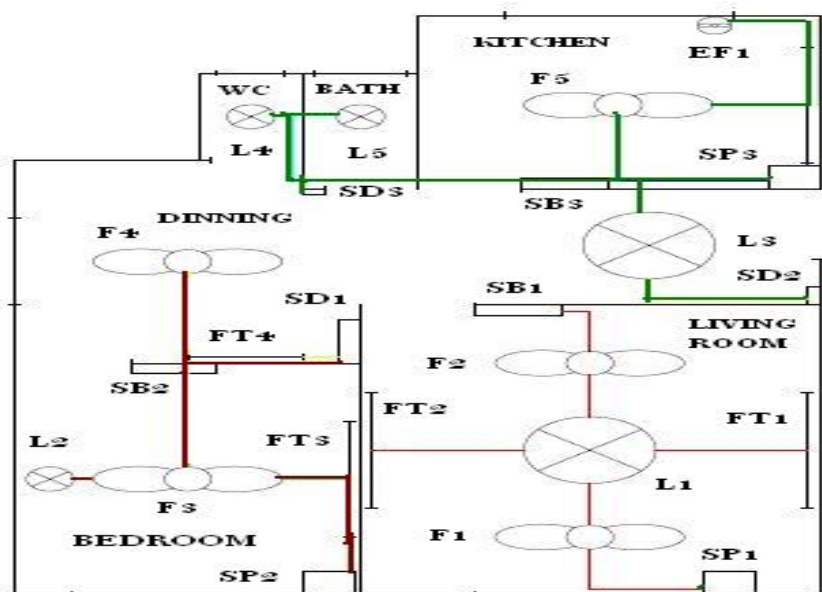

NOTATIONS USED:

SR. NO.	NOTATION	MEANING
1	F1, F2...	CEILING FAN
2	EF1	EXHAUST FAN
3	FT1, FT2...	FLUOROSCENT TUBE
4	L1, L2...	LAMP
5	SB1, SB2...	SWITCH BOARD
6	SP1, SP2...	POWER POINT BOARD
7	SD1, SD2...	SUB SWICTH BOARD

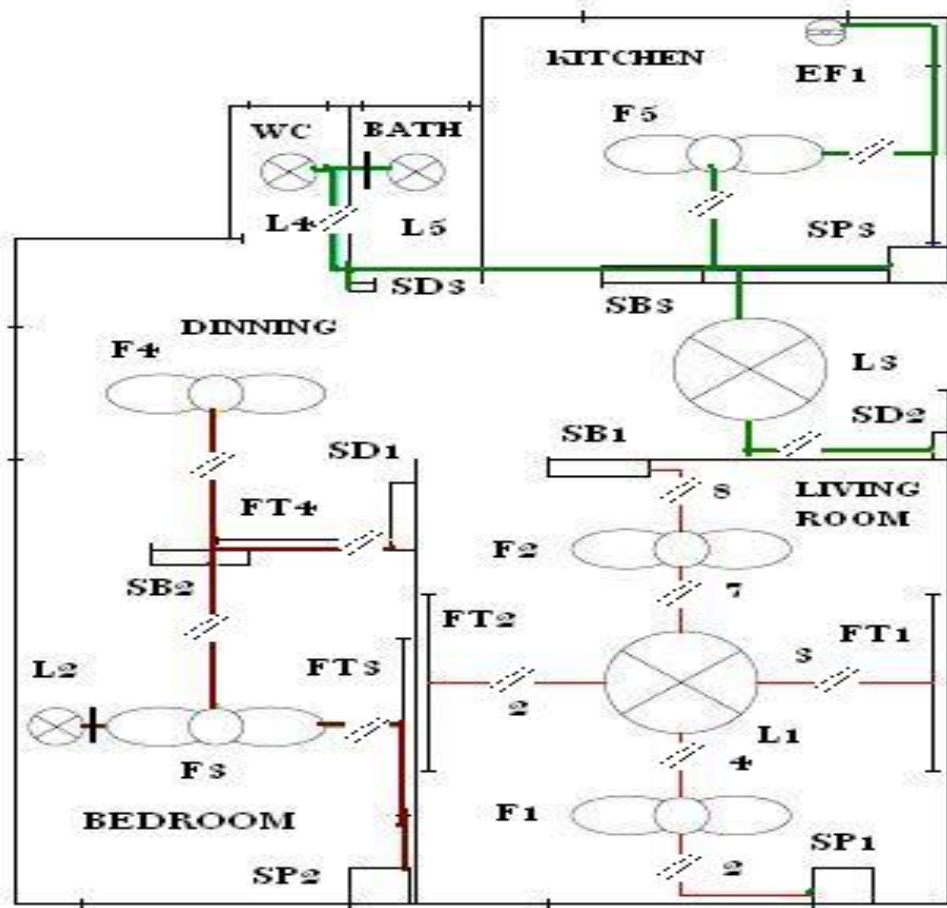
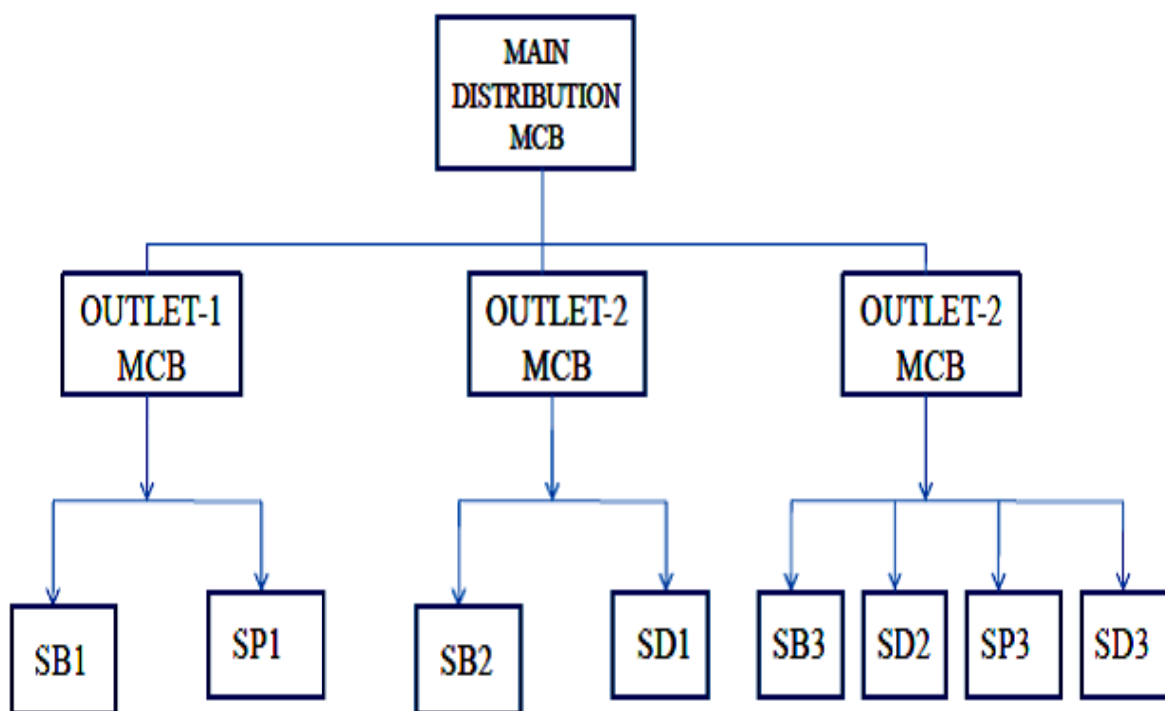

Diagram representing number of conductors in conduit

- d. Paste single line wiring diagram for the provided/ suggested to opt for the 1 BHK residential unit using Auto-cad.



Note: The staff member may suggest the student to draw the wiring diagram of any of the switch board/ wiring diagram of individual outlet.

VII Resources Required

Sr. No.	Name of Resource	Provided/ Suggested to opt for the Plan	Quantity
1	Civil consultant / Contractor/ Plan of your own flat	Plan of 1 BHK flat	1
2	Auto-cad Soft tool	-----	-----

VIII Precautions to be followed:

1. Use standard electrical symbols as per IE rule to represent the electrical installation accordingly.
2. Segregate wiring installation with proper suitable colour based on distribution outlets.
3. Clearly specify the position/location/spacing of points and distribution board with proper labeling/ numbering.
4. Segregate power and lighting installation with separate colour/ notation/ markings.

IX Procedure

1. Collect the plan and requirement of electrical points from the client/ contractor/ civil consultant/ as suggested by course teacher.
2. Draw the provided/ suggested to opt for (from collected) plan in auto-cad, clearly indicating the position of door and window.
3. Draw the appliances and distribution board, power points and light point by representing with symbols and colour coding/labeling.
4. Draw conduit route to join all the points with respective sub-distribution board by shortest distance.
5. Mark the number of conductors in respective conduit.
6. Draw electrical wiring diagram from plan drawn in step 4 and 5.
7. Prepare list of material.

X Resources Used

Sr. No.	Name of Resource	Provided/ Suggested to opt for the Plan	Quantity
1			
2			

XI Actual Procedure Followed (use blank sheet if space is not sufficient)

.....

.....

.....

.....

.....

XII Precautions Followed

.....

.....

.....

.....

XIII Assumption and Calculations (size/rating of wire, conduit and RCCB/MCB. Quote IS codes relevant to selection) (should be as per relevant IE rules and regulations)

(Use blank sheet if space is not sufficient)

XIV Results (Comment on list of material, size and rating of protective device)

.....
.....
.....
.....
.....

XV Interpretation and assumption (Made while drawing electrical plan for the given installation system) (As per IE rules related to installation)

.....
.....
.....
.....
.....

XVI Conclusions (Relevance to deciding the position of appliances, selection of shortest wiring route and its impact on costing)

.....
.....
.....
.....
.....

XVII Practical Related Questions

Note: Below given are few sample questions for reference. Teachers must design more such questions so as to ensure the achievement of identified CO.

1. Write the significance of electrical symbols in electrical drawing.
2. Write IE rule pertaining to domestic installation system.
3. Describe the procedure for selecting the size / rating of wire and MCB.
4. Illustrate the criteria to decide number of sub distribution circuits.
5. Differentiate between residential and commercial installation systems.

XVIII References / Suggestions for Further Reading

1. <https://ask-the-electrician.com/wiringdiagrams.html>
2. <https://www.btechguru.com/courses--nptel--electrical-engineering-video-lecture--ee.ht..>
3. <https://www.electricaltechnology.org/2013/09/electrical-wiring.htm>
4. <https://www.howstuffworks.com/search.php?terms=electrical%20installatio>
5. <https://www.electrical4u.com/electrical-engineering-articles/utilities/>
6. <http://www.neca-neis.org/the-standards>
7. <http://www.metlabs.com/product-safety/2011-national-electrical-code-nec-updates-standard-for-the-safe-installation-of-electri>

XIX Assessment Scheme

Performance indicators	Weight-age
Marks: 25	
Drawing using AutoCAD	40
Understanding line diagram	25
List of material	15
Answer to questions	10
Submission of report in time	10
Total	100 %

Names of Student Team Members

1.
2.
3.
4.

Marks Obtained			Dated signature of Teacher
Drawing Skill (10)	Understanding (15)	Total (25)	

Practical No.2 : Draw plan of electrical installation scheme for given small commercial unit using Auto-cad.

I Practical Significance

Every diploma electrical engineer must have the knowledge of Auto-cad for making the drawing of Commercial electrical installations and identify the symbolic representation of appliances/equipment, distribution board and their position / location as per IE rules. The safety norms must be known while carrying out installation in electrical system.

Relevant Program Outcomes (POs)

- **Discipline knowledge:** Apply Electrical Engineering knowledge to solve broad based Electrical Engineering related problems.
- **Environment and sustainability:** Apply Electrical engineering solutions for sustainable development practices in societal and environmental contexts.
- **Engineering tools:** Apply relevant Electrical technologies and tools with an understanding of the limitations.
- **The engineer and society:** Assess societal, health, safety, legal and cultural issues and the consequent responsibilities relevant to practice in the field of Electrical engineering.
- **Ethics:** Apply ethical principles for commitment to professional ethics, responsibilities and norms of the practice in the field of electrical engineering.
- **Communication:** Communicate effectively in oral and written form.

II Competency and Skills

The aim of this course is to help the student to attain the following industry identified competency through various teaching learning experiences:

- **Plan electrical installations with their cost estimates.**

III Relevant Course Outcome(s)

- Interpret various electrical diagrams.
- Prepare estimate of domestic and commercial electrical installations.

IV Practical Outcome

- Draw single line wiring diagram of above commercial installation.
- Draw the symbols of installation components on the above plan showing their location.
- Draw the installation wiring route diagram for the above plan.

V Minimum Theoretical Background

- Meaning and purpose of symbols used to represent electrical equipment in given electrical installation system.
- Application and need of electrical accessories and protective devices based on type of installation.
- Determining the Size/Rating of distribution board, wires and protective equipment.
- IE rules pertaining to all type of electrical installation.
- Knowledge of Auto-cad.

VI Plan layout/ Wiring diagram /Work Situation

- a. Paste the plan of small commercial unit whose electrical plan has to be drawn by using Auto-cad.
 - b. Paste labelled drawing representing location of installation components,
 - c. Paste wiring/ conduit route diagram join the equipments with respective distribution board through shortest route.
 - d. Paste single line wiring diagram electrical installation for any one of the switch board.
- a. Paste the provided/ suggested to opt for the plan of small commercial unit whose electrical plan has to be drawn using Auto-cad.

Plan of Primary School:

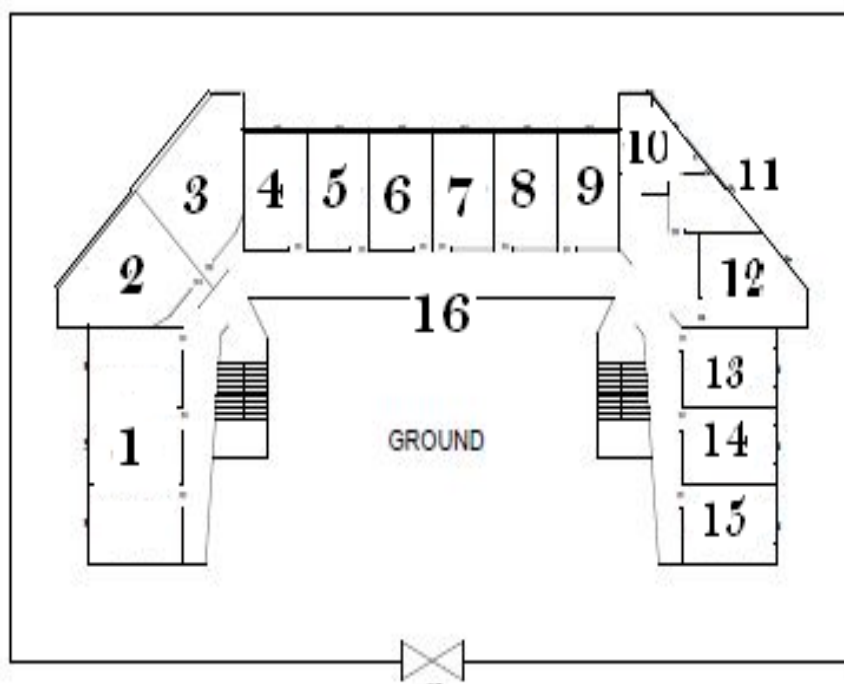

NOTATION USED:

1	Library
2, 3	Lavatory
4 to 9	Classroom
10	Staffroom
11	Principal Cabin
12	Office
13, 14, 15	Laboratory
16	Verandah

Note: The staff member has to provide/ suggest to opt any commercial unit to group of students. (A sample plan of School is given for reference).

b. Paste labelled drawing representing location of installation components for the provided/ suggested to opt for the small commercial unit using Auto-cad.

c. Paste wiring/ conduit route layout diagram to join the equipments with respective distribution board through shortest route for the provided/ suggested to opt for the small commercial unit using Auto-cad.

- d. Paste single line wiring diagram for the provided / suggested to opt for the small commercial unit using Auto-cad.

VII Resources Required

Sr. No.	Name of Resource	Provided/ Suggested to opt for the Plan	Quantity
1	Civil consultant / Contractor/ Plan of any commercial premises.	Plan of Small Commercial Unit	1
2	Auto-cad soft tool	-----	----

VIII Precautions to be followed:

1. Use standard symbols as per IE rule to represent the electrical installation accordingly.
2. Segregate wiring installation with suitable colour based on distribution outlets.
3. Clearly specify the position/location of points and distribution board with proper labeling.
4. Segregate power and lighting installation with separate colour/ marking.
5. Follows safety rule/ norms pertaining to commercial installation.

IX Procedure

1. Collect the plan and requirement of electrical points from the client/ contractor/ civil consultant.
2. Draw the stated / collected plan in auto-cad, clearly indicating the position of door, windows, entrance, emergency exit, refuge area etc.
3. Draw the appliances, distribution board, power points, light point and emergency backup circuit components by representing with symbols and colour coding/ proper labeling.
4. Draw conduit route to join all the points with respective main distribution and sub-distribution board with shortest accessible route.
5. Mark the number of conductors in respective conduit.
6. Draw electrical wiring diagram based on plan drawn in step 4 and 5.

X Resources Used

Sr. No.	Name of Resource	Provided/ Suggested to opt for the Plan	Quantity
1			
2			

XI Actual Procedure Followed (use blank sheet if space is not sufficient)

.....
.....
.....
.....
.....

XII Precautions Followed

.....
.....
.....
.....
.....

XIII Assumption and Calculations (Made while determining/ deciding the size/rating of wire, conduit and RCCB/ MCCB/ MCB) (should be as per IE rules and regulations)

(Use blank sheet if space is not sufficient)

XIV Results (Comment on rating of protective devices and its need in given installation. Quote the relevant IS codes)

.....
.....
.....
.....
.....

XV Interpretation and Assumption (Made while drawing plan of the given electrical installation) (As per IE rules and safety norms pertaining to commercial installation)

.....
.....
.....
.....

XVI Conclusions (In relevance to the extent the practical outcomes were achieved after this practical)

.....
.....
.....
.....

XVII Practical Related Questions

*Note: Below given are few sample questions for reference. Teachers must design more such questions so as to ensure the achievement of identified CO. (** Question is to be answered strictly)*

1. Determined size and rating of wire, MCCB and RCCB. **
2. Write the significance of electrical symbols specifically used in commercial installation drawing.
3. Write IE rule pertaining to commercial installation system.
4. Describe the procedure to determine the size of backup or emergency supply.
5. Differentiate between electrical power duct and L.V duct.

[Space for answers]

.....
.....
.....
.....
.....
.....

XVIII References / Suggestions for Further Reading

1. <https://ask-the-electrician.com/wiringdiagrams.html>
2. <https://www.btechguru.com/courses--nptel--electrical-engineering-video-lecture--ee.ht..>
3. <https://www.electricaltechnology.org/2013/09/electrical-wiring.htm>
4. <https://www.howstuffworks.com/search.php?terms=electrical%20installatio>
5. <https://www.electrical4u.com/electrical-engineering-articles/utilities/>
6. <http://www.neca-neis.org/the-standards>
7. <http://www.metlabs.com/product-safety/2011-national-electrical-code-nec-updates-standard-for-the-safe-installation-of-electri>

XIX Assessment Scheme

Performance indicators	Weight-age
Marks: 25	
Drawing using AutoCAD	40
Understanding line diagram	25
Calculation of size and rating	15
Answer to questions	10
Submission of report in time	10
Total	100 %

Names of Student Team Members

1.
2.
3.
4.

Marks Obtained			Dated signature of Teacher
Drawing Skill (10)	Understanding (15)	Total (25)	

Practical No. 3 : Draw plan of electrical installation scheme for given small factory / industrial unit using Auto-cad.

I Practical Significance

Every diploma electrical engineer must have the knowledge of Auto-cad for making the drawing of Small factory/ Industrial electrical installations and identify the symbolic representation of appliances/equipment, starter, main and sub- distribution board and their position / location as per IE rules. The safety norms and PPE's to be known while carrying out installation work in industrial electrical system.

Relevant Program Outcomes (POs)

- **Discipline knowledge:** Apply Electrical Engineering knowledge to solve broad based Electrical Engineering related problems.
- **Environment and sustainability:** Apply Electrical engineering solutions for sustainable development practices in societal and environmental contexts.
- **Engineering tools:** Apply relevant Electrical technologies and tools with an understanding of the limitations.
- **The engineer and society:** Assess societal, health, safety, legal and cultural issues and the consequent responsibilities relevant to practice in the field of Electrical engineering.
- **Ethics:** Apply ethical principles for commitment to professional ethics, responsibilities and norms of the practice in the field of electrical engineering.
- **Communication:** Communicate effectively in oral and written form.

II Competency and Skills

The aim of this course is to help the student to attain the following industry identified competency through various teaching learning experiences:

- **Plan electrical installations with their cost estimates.**

III Relevant Course Outcome(s)

- Interpret various electrical diagrams.
- Prepare estimate of industrial electrical installations.

IV Practical Outcome

- Draw single line wiring diagram of above industrial installation.
- Draw the symbols of installation components, starter and motor on the above plan showing their location.
- Draw the installation wiring route diagram for the above plan.

V Minimum Theoretical Background

- Meaning and purpose of symbols used to represent electrical equipment in given electrical installation system.

- Application and need of electrical accessories and protective devices based on type of installation.
- Determining the Size/Rating of distribution board, wires and protective equipment.
- IE rules pertaining to different types of electrical installation
- Selection of starter and protective relay based on rating of the motor/load.
- Knowledge of Auto-cad.

VI Plan layout/ Wiring diagram /Work Situation

- Paste the plan of Small factory/ Industrial unit whose electrical plan has to be drawn by using Auto-cad.
 - Paste labelled drawing representing location of installation components, starter and motor by standard electrical symbols.
 - Paste wiring/ conduit route diagram by join the equipment's with respective distribution board through shortest route.
 - Paste wiring diagram of electrical installation.
- a. Paste the provided/ suggested to opt the plan of Small factory/ Industrial unit whose electrical plan has to be drawn by using Auto-cad.

NOTE: The staff member has to provide/ suggest to opt a plan of any industrial unit (Ex. Flour mill, Irrigation pump, Tool making workshop Etc.) to respective group. The sample plan is given below for reference.

Plan A: Fabrication Workshop

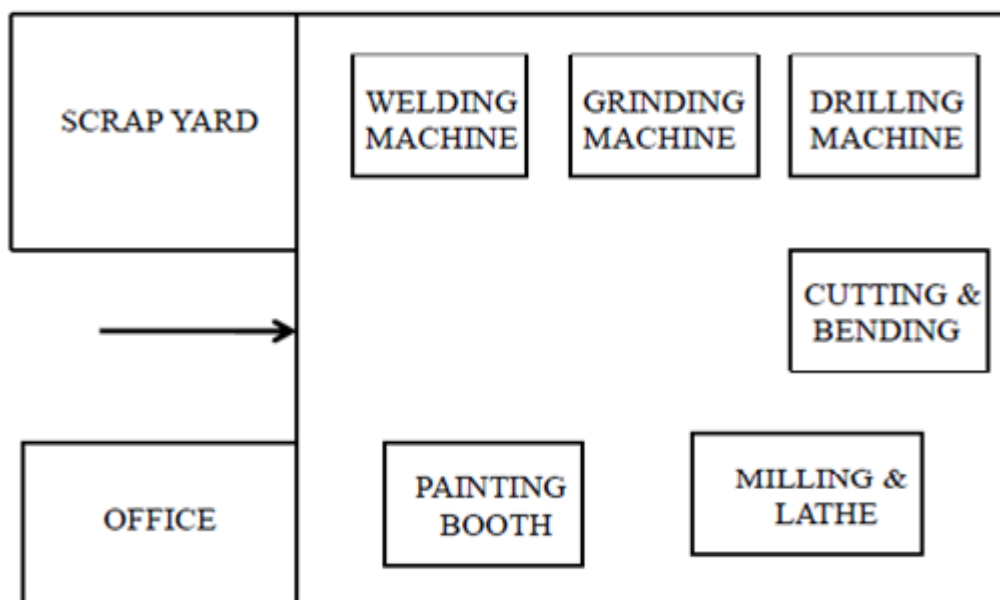

The following are the rating of machines given below, select proper protective equipment, cable and distribution board to carry out the installation. Draw the layout wiring diagram by following IE rules relevant to clearance, safety and maintenance.

Sr. No.	Name of Machine	Rating
1	Welding Machine	1 Ph, 230V, 5 KVA
2	Grinding Machine	1 Ph, 230V, 2.5 HP
3	Drilling Machine	1 Ph, 230V, 2 HP
4	Cutting & Bending Machine	3 Ph, 5 HP
5	Milling & Lathe	3 Ph, 5 HP
6	Painting Booth	1 Ph, 1 HP

NOTE: The staff member provides and explains the sequence of operation & rating of motor for two plans given.

Plan B: Tool Making Workshop.

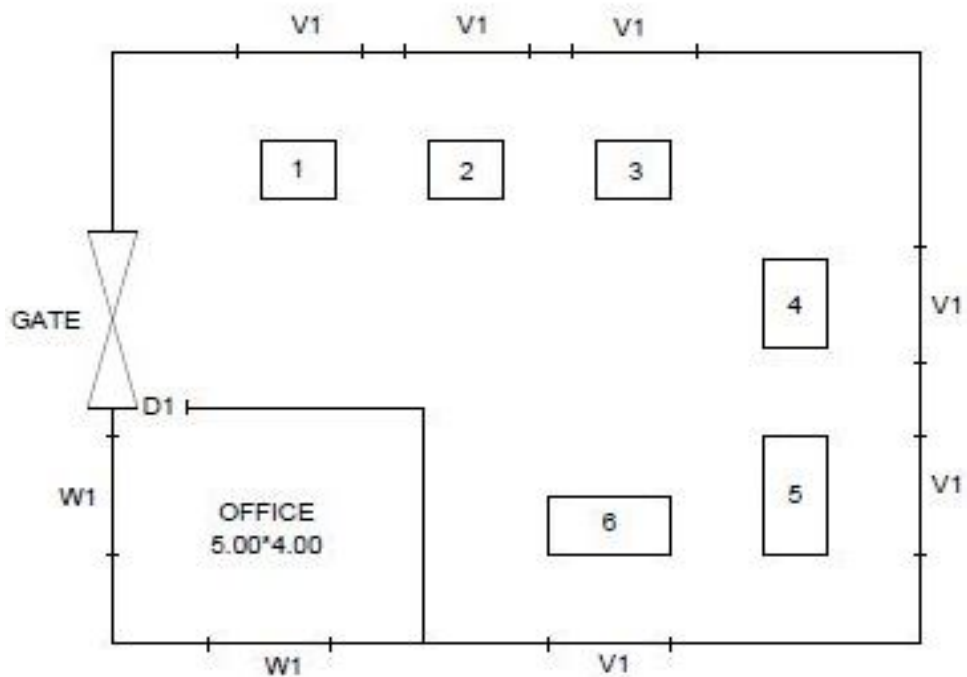

Plan C: Flour & Chilly Grinding Mill.

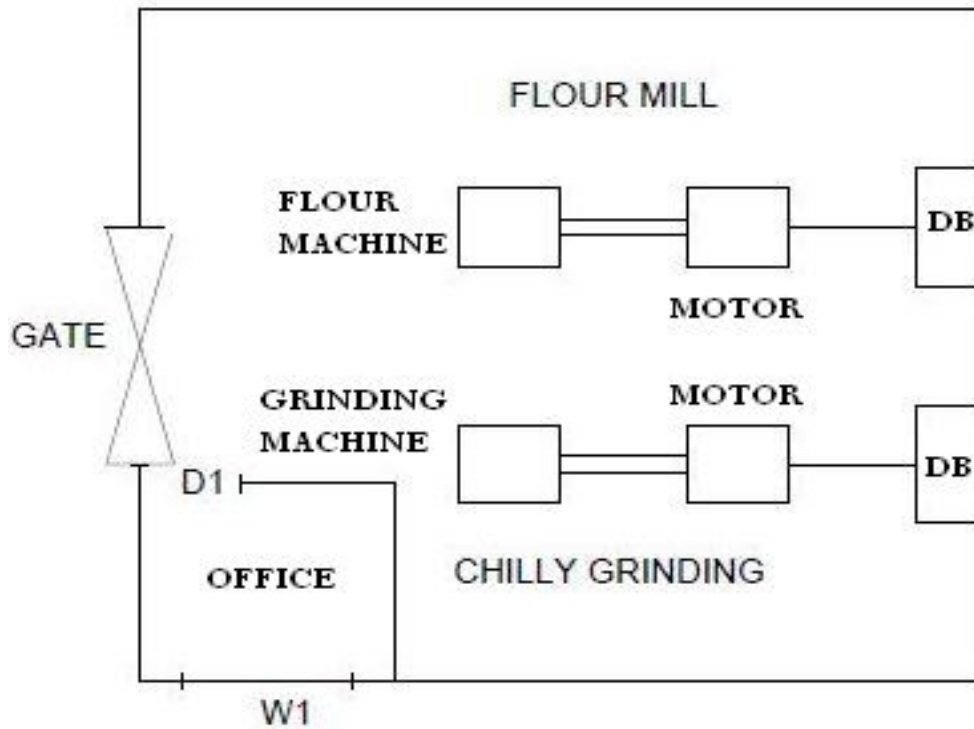

- b. Paste labeled drawing representing location of installation components, starter and motor with standard symbol for the provided/ suggested to opt for the plan of Small factory/ Industrial unit to the respective group.

- c. Paste wiring/ cable route layout diagram showing electrical connection to the equipment with respective distribution board through shortest route for the provided/ suggested to opt for the plan of Small factory/ Industrial unit
- d. Paste wiring diagram for the provided/ suggested to opt for the plan of Small factory/ Industrial unit. **(At least for Two machines).**

VII Resources Required

Sr. No.	Name of Resource	Provided/ Suggested to opt for the Plan	Quantity
1	Civil consultant / Contractor/ Plan of any Small factory/ Cottage Industrial unit	Plan of Small factory/ Cottage Industrial unit	1
2	Auto-cad soft tool	-----	-----

VIII Precautions to be followed:

1. Use standard symbols as per IE rule to represent the electrical installation accordingly.
2. Segregate wiring installation with proper colour based on distribution outlets.
3. Clearly specify the position/location of points and distribution board with proper labeling.
4. Segregate power and lighting installation with separate colour.
5. Use ferrules to label the terminals of the cable/ wire.
6. The installation of electrical machine must match with sequence of operation and finishing of product.
7. Follows safety rule/ norms pertaining to industrial installation.

IX Procedure

1. Collect the plan and requirement of electrical points/ load from the client/ contractor/ civil consultant.
2. Draw the plan in auto-cad, clearly indicating the position of door, windows, entrance, emergency exit and refuge area.
3. Draw the appliances and distribution board, power points and light point and emergency backup circuit by representing with symbols and colour coding/labeling.
4. Draw conduit route to join all the points with respective main distribution and sub-distribution board with shortest accessible route.
5. Mark the number of conductors in respective conduit.
6. Draw electrical wiring diagram based on step 4 and 5.

X Resources Used

Sr. No.	Name of Resource	Provided/ Suggested to opt for the Plan	Quantity
1			
2			

XI Actual Procedure Followed (use blank sheet if space is not sufficient)

.....
.....
.....
.....
.....

XII Precautions Followed

.....
.....
.....
.....

XIII Assumption and Calculations (Deciding the size/rating of MCCB, Distribution board and Protective relay)

(Use blank sheet if space is not sufficient)

.....
.....
.....
.....
.....
.....
.....
.....
.....
.....
.....
.....
.....
.....
.....
.....
.....
.....
.....
.....
.....
.....
.....

XIV Results (Comment on selection of starter and type of protection.

State the relevant IS codes)

.....
.....
.....
.....
.....

XV Interpretation and Assumptions (While drawing the plan of given electrical installation) (As per IE rules and safety norms pertaining to commercial installation)

.....
.....
.....
.....
.....

XVI Conclusions (In relevance to deciding the position of appliances and selection of shortest wiring route and its impact on costing)

.....
.....
.....
.....
.....

XVII Practical Related Questions

*Note: Below given are few sample questions for reference. Teachers must design more such questions so as to ensure the achievement of identified CO. (** Question is to be answered strictly)*

1. Determined rating of starter and relay and suggest its type for the given plan. **
2. State the different protective systems used in industrial installation with their specific applications.
3. Write IE rule pertaining to industrial installation system.
4. Differentiate between commercial and industrial installation.

[Space for answers]

.....
.....
.....
.....
.....

XVIII References / Suggestions for Further Reading

1. <https://ask-the-electrician.com/wiringdiagrams.html>
2. <https://www.btechguru.com/courses--nptel--electrical-engineering-video-lecture--ee.ht..>
3. <https://www.electricaltechnology.org/2013/09/electrical-wiring.htm>
4. <https://www.howstuffworks.com/search.php?terms=electrical%20installatio>
5. <https://www.electrical4u.com/electrical-engineering-articles/utilities/>
6. <http://www.neca-neis.org/the-standards>
7. <http://www.metlabs.com/product-safety/2011-national-electrical-code-nec-updates-standard-for-the-safe-installation-of-electri>

XIX Assessment Scheme

Performance indicators	Weight-age
Marks: 25	
Drawing using AutoCAD	40
Understanding line diagram	20
Selection of Starter and required Protective scheme	20
Answer to sample questions	10
Submission of report in time	10
Total	100 %

Names of Student Team Members

1.
2.
3.
4.

Marks Obtained			Dated signature of Teacher
Drawing Skill (10)	Understanding (15)	Total (25)	

Practical No. 4 : Draw plan of electrical installation scheme for given HT (11kV) connection using Auto-cad.

I Practical Significance

Every diploma electrical engineer must be well aware of the various component of HV installation system with their location and application, this helps him to prepare plan layout drawing of given HV installation. He can execute the work at utmost care ensuing the IE rules and safety norms.

Relevant Program Outcomes (POs)

- **Discipline knowledge:** Apply Electrical Engineering knowledge to solve broad based Electrical Engineering related problems.
- **Environment and sustainability:** Apply Electrical engineering solutions for sustainable development practices in societal and environmental contexts.
- **Engineering tools:** Apply relevant Electrical technologies and tools with an understanding of the limitations.
- **The engineer and society:** Assess societal, health, safety, legal and cultural issues and the consequent responsibilities relevant to practice in the field of Electrical engineering.
- **Ethics:** Apply ethical principles for commitment to professional ethics, responsibilities and norms of the practice in the field of electrical engineering.
- **Communication:** Communicate effectively in oral and written form.

II Competency and Skills

The aim of this course is to help the student to attain the following industry identified competency through various teaching learning experiences:

- **Plan electrical installations with their cost estimates.**

III Relevant Course Outcome(s)

- Interpret various electrical diagrams.
- Prepare estimate of overhead and underground distribution lines (HT Lines)

IV Practical Outcome

- Draw single line wiring diagram of below HT (11kV) installation.
- Draw the symbols of installation components along with equipments (i.e. Transformer, CT, PT and ACB) on the below plan showing their location.
- Draw the installation wiring route diagram for the below plan.

V Minimum Theoretical Background

- Meaning and purpose of symbols used to represent electrical equipment in given electrical installation system.
- Application and need of electrical accessories and protective devices based on type of installation.
- Determining the Size/ Rating of distribution board, cable, ACB/ OCB, CT, PT, Isolator and protective equipment.
- IE rules pertaining to HV electrical installation.
- Safety norms in planning, execution and commissioning.
- Knowledge of Auto-cad.

VI Plan layout/ Wiring diagram /Work Situation

- a. Paste electrical installation scheme for provided/ suggested to opt for the HT (11kV) installation drawing drawn using Auto-cad.

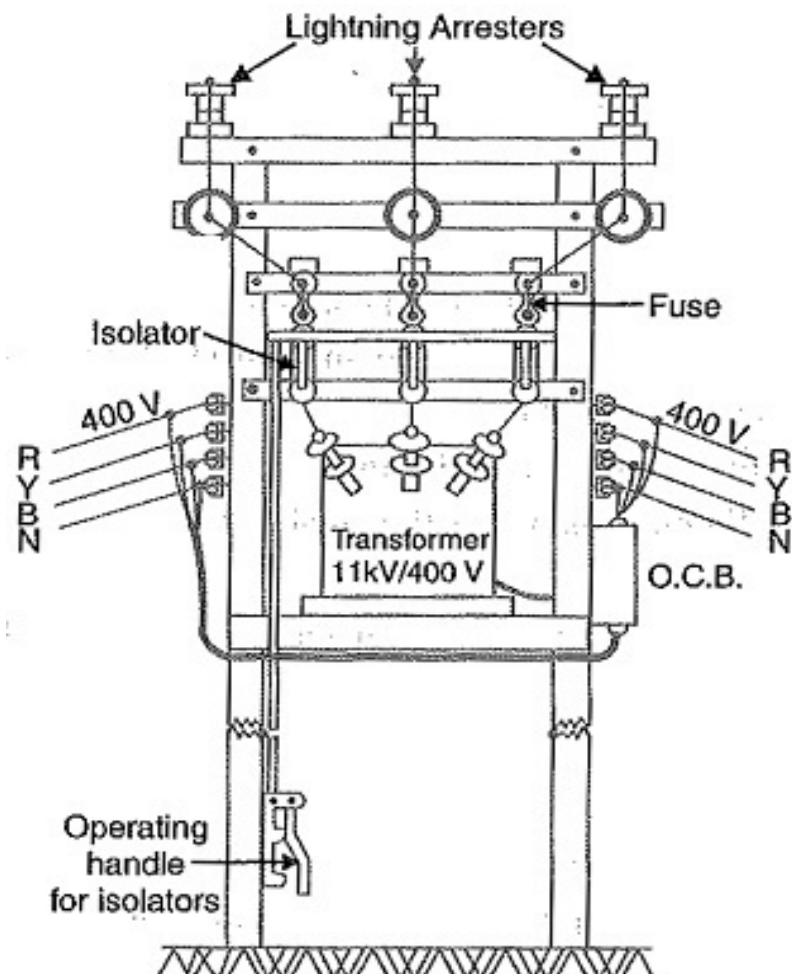

- b. Paste single line wiring diagram of provided/ suggested to opt for the HT (11kV) installation drawing drawn using Auto-cad.

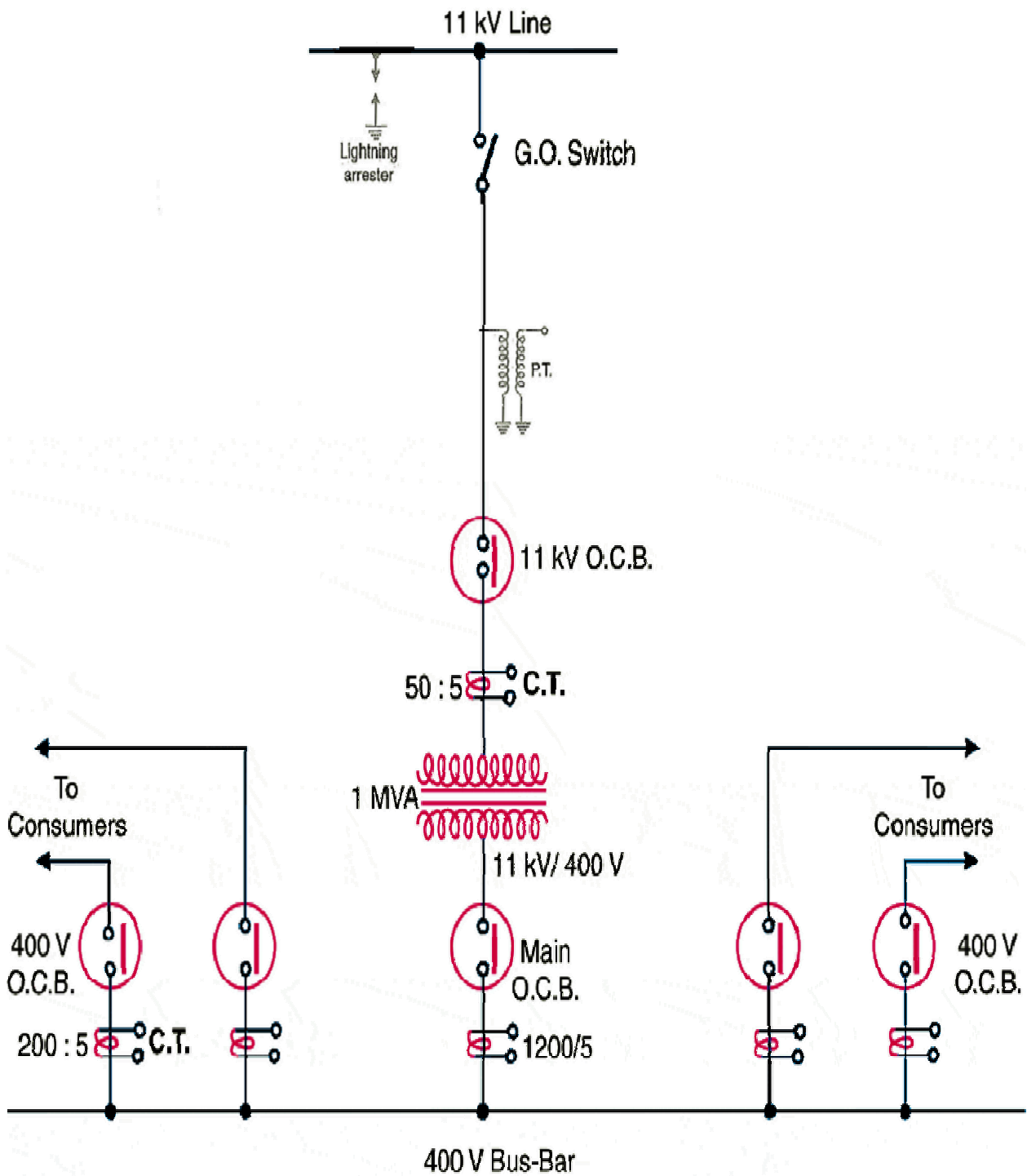

VII Resources Required

Sr. No.	Name of Resource	Provided/ Suggested to opt for the Plan	Quantity
1	Client/ HT Installation plan from Industry/Commercial	HT installation scheme (Indoor / Outdoor)	1
2	Auto-cad soft tool	-----	-----

VIII Precautions to be followed:

1. Use standard symbols as per IE rule to represent the electrical installation accordingly.
2. Use ferrules to labelling the terminals of the cable/ wires.
3. Specify proper clearance/ distance between the equipment as per IE rules
4. Follows safety rule/ norms pertaining to industrial installation.
5. Use sign boards/ safety symbols.

IX Procedure

1. Collect the plan and requirement of H.T station from the client/ contractor/ civil consultant/ as suggested by staff member.
2. Draw the provided/ suggested to opt for plan using auto-cad.
3. Draw the layout of HV installation representing the location of transformer, cable route and all the accessories with protective equipment with standard symbols.
4. Specify the clearance clearly where ever it is essential.
5. Use colour labelling to make the drawing easy to understand.

X Resources Used

Sr. No.	Name of Resource	Provided/ Suggested to opt for the Plan	Quantity
1			
2			

XI Actual Procedure Followed (use blank sheet if space is not sufficient)

.....

.....

.....

.....

.....

XII Precautions Followed

.....
.....
.....
.....
.....

XIII Assumption and Calculations (Deciding the size/rating CT, PT, Distribution board)

(Use blank sheet if space is not sufficient)

XIV Results (Comment on LA and Drop fuse selection criteria)

.....
.....
.....
.....
.....

XV Interpretation and Assumptions (Made while deciding the position and location of electrical equipments according to IE rules)

.....
.....
.....
.....
.....

XVI Conclusions (Factors considered while selecting the location for substation)

.....
.....
.....
.....
.....

XVII Practical Related Questions

*Note: Below given are few sample questions for reference. Teachers must design more such questions so as to ensure the achievement of identified CO. (** Question is to be answered strictly)*

1. Determined the rating of CT, PT and circuit breaker for 500 kVA, 11KV transformer. **
2. State IE rule pertaining to HV installation system.
3. Describe the procedure to determine the size of transformer and cable.
4. State the factors considered while selecting site for HT substation installation.
5. Describe the function of Lightning arrester and drop fuse.
6. State specific requirements for Indoor and Outdoor substation.

[Space for answers]

.....
.....
.....
.....
.....
.....
.....
.....
.....
.....
.....
.....
.....
.....
.....
.....
.....
.....
.....
.....
.....
.....

XVIII References / Suggestions for Further Reading

1. <https://ask-the-electrician.com/wiringdiagrams.html>
2. <https://www.btechguru.com/courses--nptel--electrical-engineering-video-lecture--ee.ht..>
3. <https://www.electricaltechnology.org/2013/09/electrical-wiring.htm>
4. <https://www.howstuffworks.com/search.php?terms=electrical%20installatio>
5. <https://www.electrical4u.com/electrical-engineering-articles/utilities/>
6. <http://www.neca-neis.org/the-standards>
7. <http://www.metlabs.com/product-safety/2011-national-electrical-code-nec-updates-standard-for-the-safe-installation-of-electri>

XIX Assessment Scheme

Performance indicators	Weight-age
Marks: 25	
Drawing using AutoCAD	40
Understanding line diagram	20
Selection of protective equipment and accessories	20
Answer to sample questions	10
Submission of report in time	10
Total	100 %

Names of Student Team Members

1.
2.
3.
4.

Marks Obtained			Dated signature of Teacher
Drawing Skill (10)	Understanding (15)	Total (25)	

Practical No. 5 : Draw plan of electrical installation scheme for given LT (415V) line connection using Auto-cad.

I Practical Significance

Every diploma electrical engineer must familiar with requirements of LT equipment, protective accessories, their function, location and the knowledge of Auto-cad for making drawing electrical installations as per IE rules. The safety norms to be known followed strictly while carrying out installation.

Relevant Program Outcomes (POs)

- **Discipline knowledge:** Apply Electrical Engineering knowledge to solve broad based Electrical Engineering related problems.
- **Environment and sustainability:** Apply Electrical engineering solutions for sustainable development practices in societal and environmental contexts.
- **Engineering tools:** Apply relevant Electrical technologies and tools with an understanding of the limitations.
- **The engineer and society:** Assess societal, health, safety, legal and cultural issues and the consequent responsibilities relevant to practice in the field of Electrical engineering.
- **Ethics:** Apply ethical principles for commitment to professional ethics, responsibilities and norms of the practice in the field of electrical engineering.
- **Communication:** Communicate effectively in oral and written form.

II Competency and Skills

The aim of this course is to help the student to attain the following industry identified competency through various teaching learning experiences:

- **Plan electrical installations with their cost estimates.**

III Relevant Course Outcome(s)

- Interpret various electrical diagrams.
- Prepare estimate of overhead and underground distribution lines (LT).

IV Practical Outcome

- Draw the installation wiring route diagram for the LT (415V) electrical installation.
- Draw single line wiring diagram of LT (415V) installation.

V Minimum Theoretical Background

- Meaning and purpose of symbols used to represent electrical equipment in given electrical installation system.

- Application and need of electrical accessories and protective devices based on type of installation.
- Determining the Size/Rating of distribution board, CT, connecting cables and protective equipment.
- IE rules pertaining to all type of electrical installation
- Selection MCB/MCCB/ fuse unit and protective relay-based load on the installation system.
- Knowledge of Auto-cad.

VI Plan layout/ Wiring diagram /Work Situation

- Draw single line wiring diagram of below LT (415V) installation.
 - Draw the symbols of installation components along with equipments (i.e. Busbar, CT, PT and MCCB) on the below plan showing their location.
 - Draw the installation wiring route diagram for the below plan.
- a. Paste single line wiring diagram of provided/ suggested to opt for the LT (415V) installation.

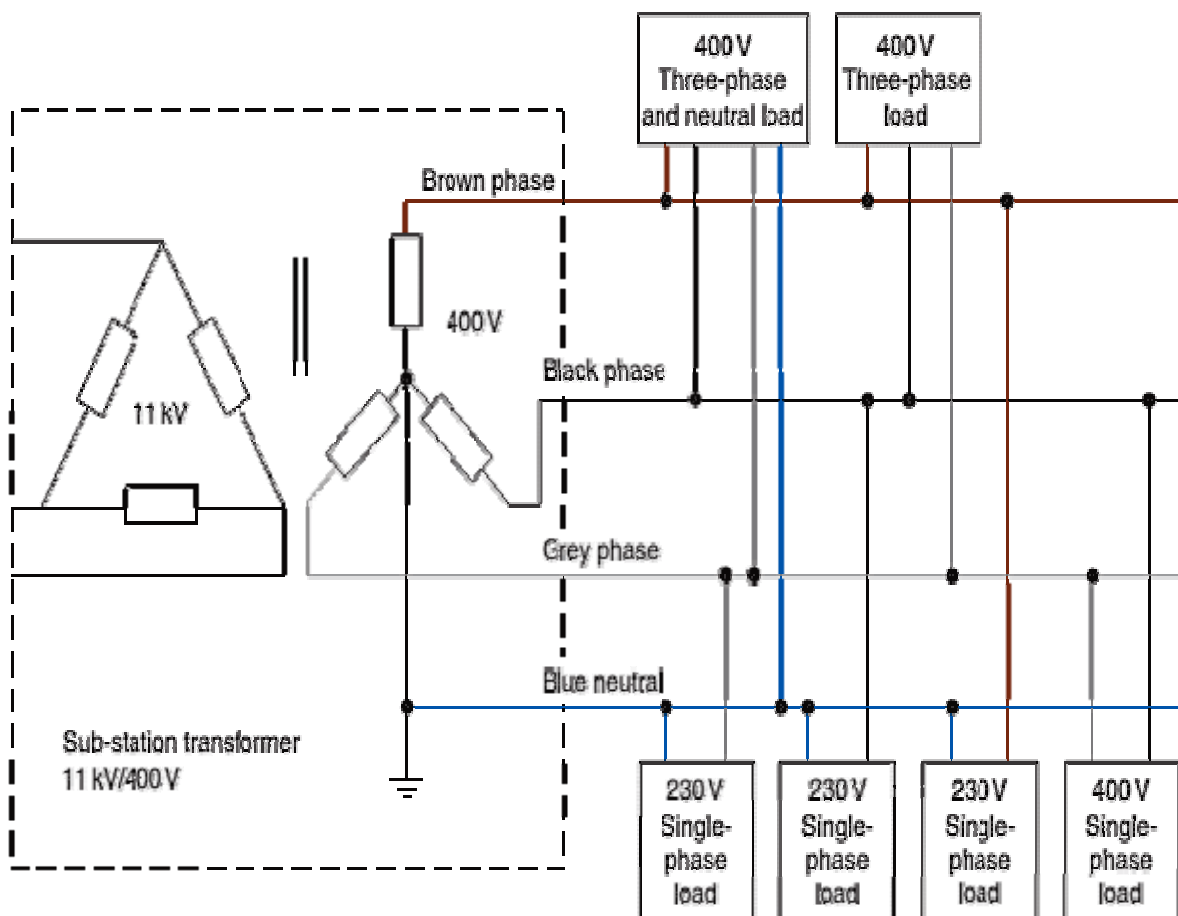

- b. Draw using AutoCAD the symbol of installation components along with equipments (i.e. Busbar, CT, PT and MCCB) on provided/ suggested to opt for the LT (415V) plan showing their location (For Overhead and Underground service connection).

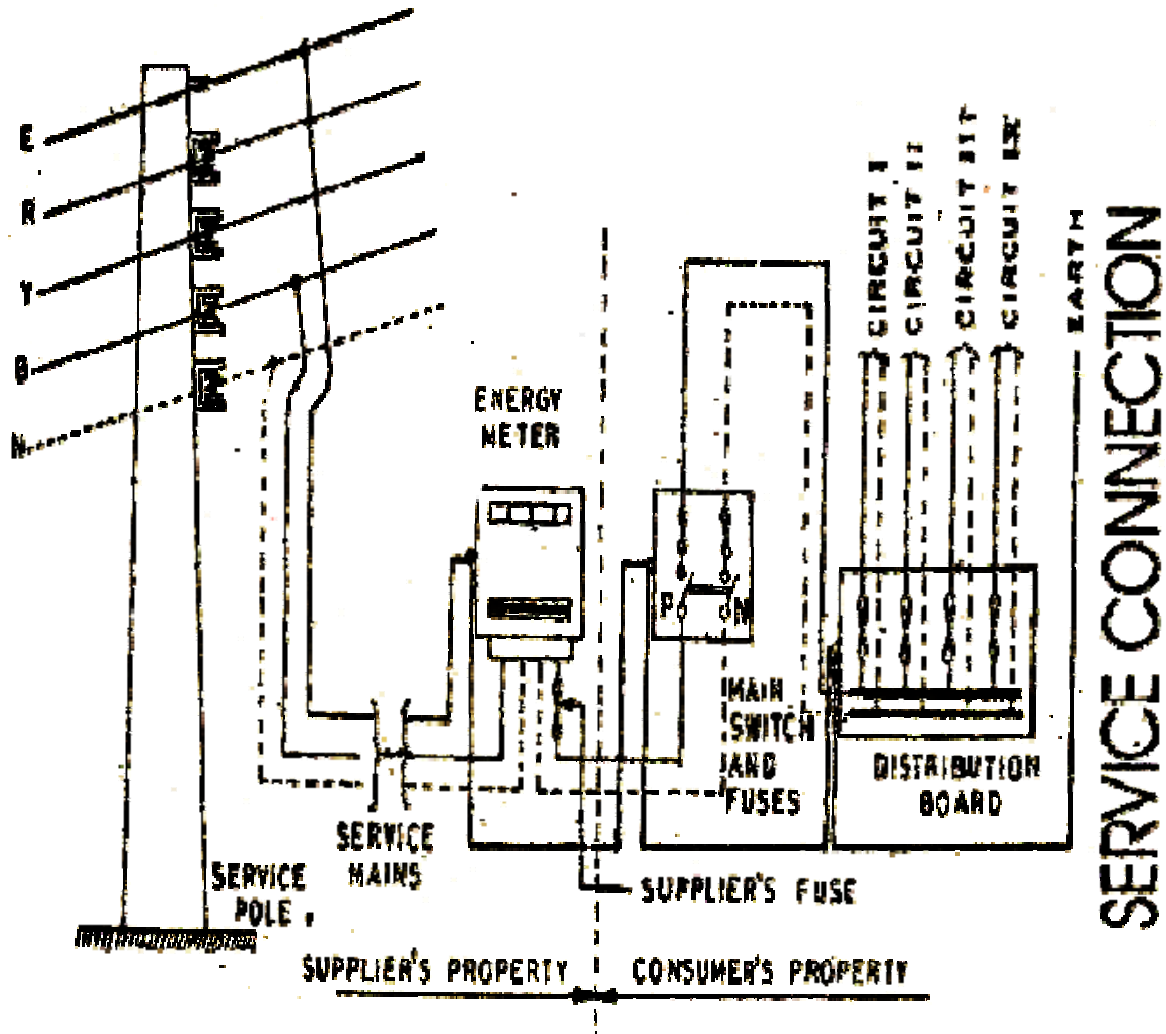

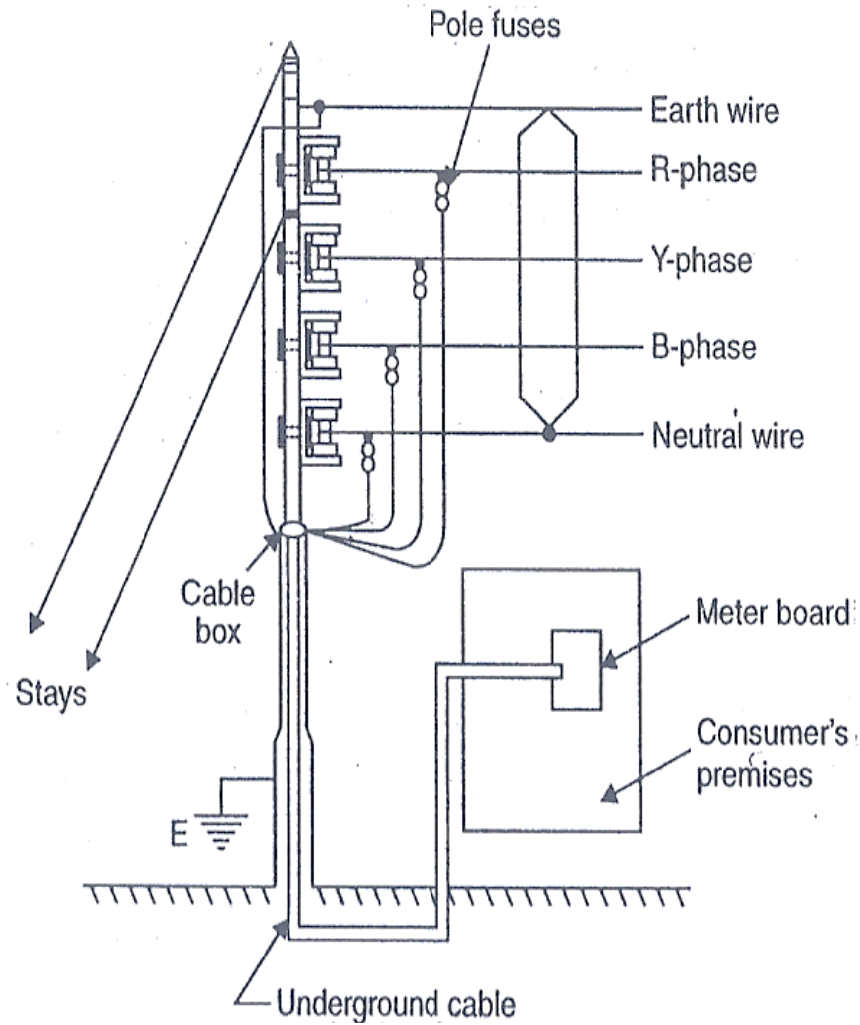

Note: Sample diagram of overhead and underground service mains given for reference.

- c. Paste the installation wiring route diagram of underground/ overhead service connection.

VII Resources Required

Sr. No.	Name of Resource	Provided/ Suggested to opt for the Plan	Quantity
1	Information from client/consumer	Selection of type of service connection	1
2	Auto-cad soft tool	-----	-----

VIII Precautions to be followed:

1. Use standard symbols as per IE rule to represent the electrical installation accordingly.
2. Segregate wiring installation with proper colour based on distribution outlets.
3. Clearly specify the position/location of points and distribution board with proper labeling.
4. Segregate power and lighting installation with separate colour.
5. Use ferrules to label the terminals of the cable/ wire.
6. The installation of electrical machine must match with sequence of operation and finishing of product.
7. Follows safety rule/ norms pertaining to industrial installation.

IX Procedure

1. Collect the information about connected load of the client/ consumer.
2. Choose size and rating of cable, distribution board and fuse.
3. Select shortest route to convey power from distribution pole/ terminal to consumer premises.
4. Based on locality and type of consumer select service connection.
5. Draw service connection diagram by using AutoCAD.

X Resources Used

Sr. No.	Name of Resource	Provided/ Suggested to opt for the Plan	Quantity
1			
2			

XI Actual Procedure Followed (use blank sheet if space is not sufficient)

.....

.....

.....

.....

.....

XII Precautions Followed

.....
.....
.....
.....
.....
.....
.....
.....
.....
.....

XIII Assumption and Calculations (Made while selecting the materials and rating of protective equipments used in installation as per IE rules and regulations).

(Use blank sheet if space is not sufficient)

XIV Results (Comment on CT ratio, MCB rating and state relevant IS codes)

.....
.....
.....
.....
.....

XV Interpretation and Assumptions (While choosing the route and type of service connections)

.....
.....
.....
.....
.....

XVI Conclusions (In relevance to selecting the type of service mains, shortest laying route, size and rating of distribution etc.)

.....
.....
.....
.....
.....

XVII Practical Related Questions

*Note: Below given are few sample questions for reference. Teachers must design more such questions so as to ensure the achievement of identified CO. (** Question is to be answered strictly)*

1. State the reason for selection of type of service main and rating of D.B. **
2. Describe the factors governing the selection of type of service connection.
3. Distinguished between underground and overhead service connection.
4. List the properties and important features of cable used for underground service connection.

[Space for answers]

.....
.....
.....
.....
.....

XVIII References / Suggestions for Further Reading

1. <https://ask-the-electrician.com/wiringdiagrams.html>
2. <https://www.btechguru.com/courses--nptel--electrical-engineering-video-lecture--ee.ht..>
3. <https://www.electricaltechnology.org/2013/09/electrical-wiring.htm>
4. <https://www.howstuffworks.com/search.php?terms=electrical%20installatio>
5. <https://www.electrical4u.com/electrical-engineering-articles/utilities/>
6. <http://www.neca-neis.org/the-standards>
7. <http://www.metlabs.com/product-safety/2011-national-electrical-code-nec-updates-standard-for-the-safe-installation-of-electri>

XIX Assessment Scheme

Performance indicators	Weight-age
Marks: 25	
Drawing using AutoCAD	40
Understanding line diagram	20
Selection of type of service mains and rating of D. B	20
Answer to sample questions	10
Submission of report in time	10
Total	100 %

Names of Student Team Members

1.
2.
3.
4.

Marks Obtained			Dated signature of Teacher
Drawing Skill (10)	Understanding (15)	Total (25)	

Practical No. 6 : Draw plan of public lighting installation scheme of given premises using Auto-cad.

I Practical Significance

Every diploma electrical engineer must have the knowledge about the significance of public lighting scheme. The knowledge of Auto-cad for making drawing of given public lighting installations by using standard symbol to represent equipment, distribution board etc. and their position / location as per IE rules.

Relevant Program Outcomes (POs)

- **Discipline knowledge:** Apply Electrical Engineering knowledge to solve broad based Electrical Engineering related problems.
- **Environment and sustainability:** Apply Electrical engineering solutions for sustainable development practices in societal and environmental contexts.
- **Engineering tools:** Apply relevant Electrical technologies and tools with an understanding of the limitations.
- **The engineer and society:** Assess societal, health, safety, legal and cultural issues and the consequent responsibilities relevant to practice in the field of Electrical engineering.
- **Ethics:** Apply ethical principles for commitment to professional ethics, responsibilities and norms of the practice in the field of electrical engineering.
- **Communication:** Communicate effectively in oral and written form.

II Competency and Skills

The aim of this course is to help the student to attain the following industry identified competency through various teaching learning experiences:

- **Plan electrical installations with their cost estimates.**

III Relevant Course Outcome(s)

- Interpret various electrical diagrams.
- Prepare estimate of public lighting installations.

IV Practical Outcome

- Draw plan showing location of street light stays and route of the cable.
- Draw actual wiring diagram of above street light installation.

V Minimum Theoretical Background

- Meaning and purpose of symbols used to represent electrical equipment in given electrical installation system.

- Application and need of electrical accessories and protective devices based on type of installation.
- IE rules pertaining to all type of electrical installation.
- Standard Illumination level required for different public lighting scheme.
- Significance and design procedure of public lighting scheme.
- Knowledge of Auto-cad.

VI Plan layout/ Wiring diagram /Work Situation:

Note: The staff member required to suggest/ provide different numerical on public lighting scheme to respective group.

- Paste plan showing location of street lamppost and stay wire drawn by using Auto-cad.
- Paste actual wiring diagram of street lamppost installation.

(Sample wiring diagram is given for reference)

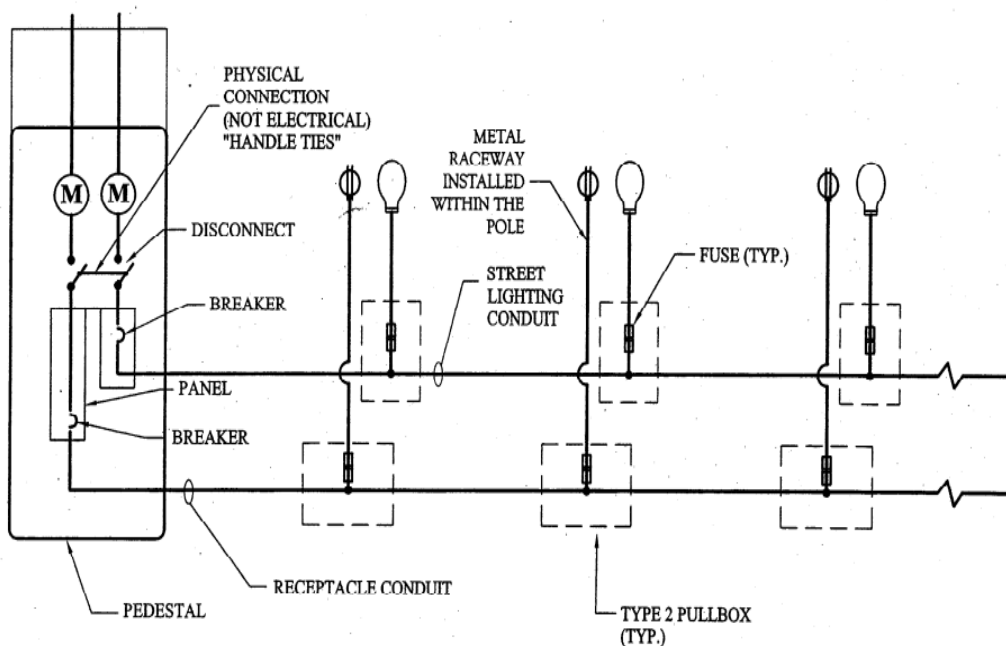

Single line diagram of Twinkle street lighting

VII Resources Required

Sr. No.	Name of Resource	Suggested Plan	Quantity
1	Textbook/ Any public lighting design journal	Numerical on public lighting scheme	1
2	Auto-cad soft tool	-----	----

VIII Precautions to be followed:

1. Use standard symbols as per IE rules to represent the electrical installation accordingly.
2. Segregate wiring installation with proper colour based on distribution outlets.
3. Clearly specify the distance between lamppost, height of the pole, angle of inclination of lamp etc.
4. Follow safety rules/ norms pertaining to public lighting installation.
5. Follow IE rules and regulations pertaining to public lighting installation.

IX Procedure

1. Calculate the number of lamppost required for given road lighting.
2. Follow the sample procedure given below to determine the necessary information to design street lighting.
3. Draw lighting scheme by using auto-cad, clearly indicating the span and position of lamppost.
4. Show the position of distribution board.

Street light Design procedure:

Typical Calculation of Road Lighting:

Luminaries are properly selected and mounted on a location most feasible and effective with minimum cost. For a 230 volts system, a voltage drop of 5% is allowed although in extreme cases 15% voltage drop is sometimes tolerated.

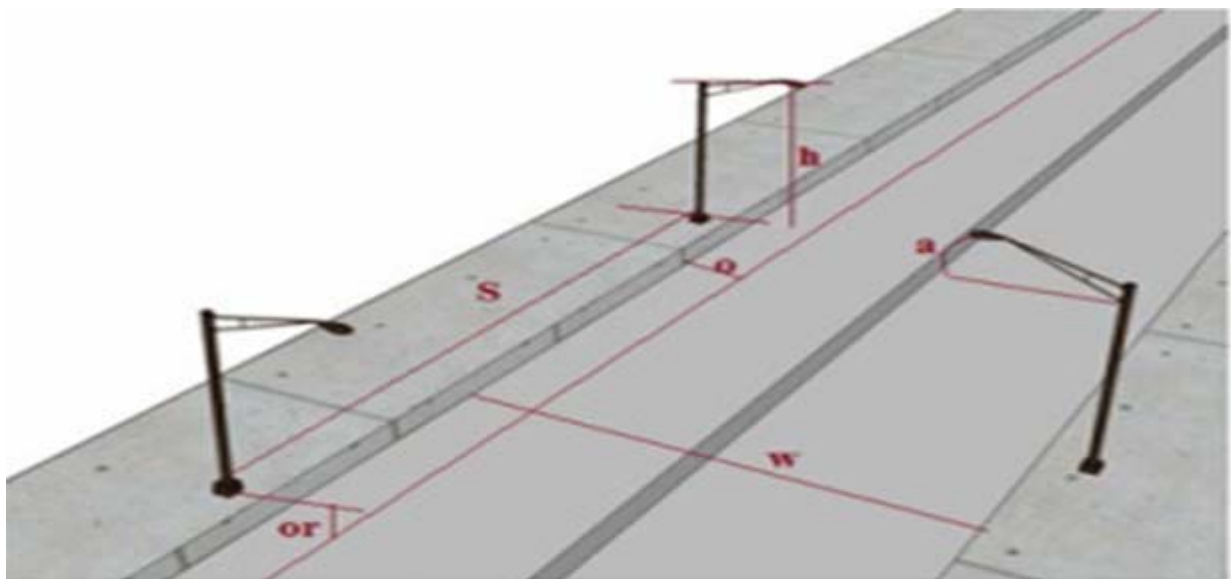

Street Lighting Features (BIS 1981)

a: Angle of Tilt or: Outreach s: Spacing w: Width h: Mounting Height
o: Overhang

- **Street illumination level in Lux (E)=(Al x (CoU x mf)) / (w x d)**
- **E = The illumination in Lux**
- **w = Width of the roadway**
- **d = Distance between luminaries**
- **CoU = Coefficient of Utilization. Which is dependent on the type of fixture, mounting height, width of roadway and the length of mast arm of outreach?**
- **Al = Average lumens: Al = (E x w x d) / CoU x mf**
- **The typical value of Al is (For Sodium Vapour / Halogen)**
- **20500 lumens for 400 watts**
- **11500 lumens for 250 watts**
- **5400 lumens for 125 watts**
- **The value of Al varies depending upon the type of lamp specified.**
- **mf: It is the maintenance factor (Normally 0.8 to 0.9)**

1. Calculate Lamp watt for street Light Pole:

- Calculate Lamp Lumen for street Light Pole having Road width of 7-meter, distance between two Pole is 50-meter, Maintenance factor is 0.9, Coefficient of utilization factor is 0.29, light pedestrian traffic is medium and Vehicular traffic is very light and Road is concrete road.

Comparative Lumens Output of Different Lamps

Factor	Lamp Type					
	Incandescent	Fluorescent	Metal Halide	High-Pressure Sodium	Low-Pressure Sodium	LED
Wattage	25-150	18-95	50-400	50-400	18-180	45-200
Output (Lumens)	210-2700	1000-7500	1900-30000	1800-33000	1800-33000	5800-20000

Recommended by IES Standard Practice for Roadway Lighting, RP-8, 2000

Name of Public Place	Required Illumination level
Stairways	4 Lux
Bikeways & Roadways	10 Lux
Mid- Block Crosswalks	34 Lux
Parking lots	22 Lux
Bus stop/ Public facilities	25 Lux

Solution:

The Recommended illumination (E) for roadway is 10 lux which is for extreme condition, by assuming the required Lux is 6.46 per sq. meter.

$$w = 7.00 \text{ meters, } d = 50 \text{ meters, } mf = 0.9, \text{ CoU} = 0.29$$

To decide Lamp Watt, it is necessary to calculate Average Lumens of Lamp (Al).

- Average Lumen of Lamp (Al)= (E x w x d) / CoU x mf
- Al= (6.46x7x50)/ (0.29x0.9) = 8662.83 Average lumen

Lamp lumen of a 250 watts lamp is 11,500 lm which is the nearest value to 8662.83 lumen. Therefore, a 250 watts lamp is acceptable.

Let's computing for the actual illumination E for 250Watt Lamp

- Illumination (E)= (Al x (cu x mf)) / (w x d)
- E= (11500x0.29x0.9) / (7x50) = 8.57 lumen per sq. meter.

Conclusion:

Actual illumination (E) for 250 Watt is 8.57lumen per sq. meter which is higher than recommended illumination (E) 6.46.

Hence 250 watt gives adequately lighting.

2. Calculate Spacing between two Light Poles (Lamppost):

- Calculate Space between Two Pole of Street Light having Fixture Watt is 250W , Lamp output of the Lamp (LL) is 33200 lumens , Required Lux Level (E) is 5 lux , Width of the road = 11.48 feet (3.5 M),Height of the pole (H) = 26.24 feet (8 M) ,Coefficient of utilization (CoU) = 0.18, Lamp Lumen Depreciation Factor (LLD) = 0.8 ,Luminaries dirt Depreciation Factor (LDD) = 0.9

Solution:

- Luminaries Spacing (S) = (LL x CoU x LLD x LDD) / (E x W)
- Luminaries Spacing (S) = (33200x0.18x0.9x0.8) / (5x11.48)
- Luminaries Spacing (S) = 75 feet (23 Meters)

X Resources Used

Sr. No.	Name of Resource	Suggested Plan	Quantity
1			
2			

XI Actual Procedure Followed (use blank sheet if space is not sufficient)

.....

.....

.....

.....

.....

.....

.....

.....

.....

.....

XII Precautions Followed

.....
.....
.....
.....
.....
.....
.....
.....
.....
.....

XIII Assumption and Calculations (Spacing between lamppost, height of pole & rating of lamp).

(Use blank sheet if space is not sufficient)

XIV Results (Importance of public lighting scheme. Relevant IS code)

.....
.....
.....
.....
.....

XV Interpretation and Assumptions (While planning for electrical installation for street lighting in given practical)

.....
.....
.....
.....
.....

XVI Conclusions (Selection of level of illumination based on traffic density and type of the road)

.....
.....
.....
.....
.....

XVII Practical Related Questions

Note: Below given are few sample questions for reference. Teachers must design more such questions so as to ensure the achievement of identified CO.

1. List out the illumination level required for different public lighting scheme.
2. Write IE rule pertaining to above electrical installation system.
3. Differentiate between Flood lighting and Road lighting.
4. Discuss the factors consider while installation of lighting in tunnels.

[Space for answers]

.....
.....
.....
.....
.....
.....
.....

.....
.....
.....
.....
.....
.....
.....
.....
.....
.....
.....
.....
.....
.....
.....
.....
.....
.....
.....
.....
.....
.....
.....
.....
.....
.....
.....
.....
.....
.....
.....
.....
.....
.....
.....
.....
.....
.....
.....
.....
.....
.....
.....
.....
.....
.....
.....

XVIII References / Suggestions for Further Reading

1. <https://ask-the-electrician.com/wiringdiagrams.html>
2. <https://www.btechguru.com/courses--nptel--electrical-engineering-video-lecture--ee.ht..>
3. <https://www.electricaltechnology.org/2013/09/electrical-wiring.htm>
4. <https://www.howstuffworks.com/search.php?terms=electrical%20installatio>
5. <https://www.electrical4u.com/electrical-engineering-articles/utilities/>
6. <http://www.neca-neis.org/the-standards>
7. <http://www.metlabs.com/product-safety/2011-national-electrical-code-nec-updates-standard-for-the-safe-installation-of-electri>

XIX Assessment Scheme

Performance indicators	Weight-age
Marks: 25	
Drawing using AutoCAD	40
Understanding line diagram	25
Selection of rating of lamp, height of pole	15
Answer to sample questions	10
Submission of report in time	10
Total	100 %

Names of Student Team Members

1.
2.
3.
4.

Marks Obtained			Dated signature of Teacher
Drawing & Design (15)	Understanding (10)	Total (25)	

Practical No.7 : Prepare tender documents, quotations and bills for specified work.

I Practical Significance

Every diploma electrical engineer must have the knowledge to prepare tender documents, quotations and bills for any specified work based on locality of installation. The student gain the idea of application and costing of main, auxiliary, protective, energy efficient equipment required to carry out the installation.

Relevant Program Outcomes (POs)

- **Discipline knowledge:** Apply Electrical Engineering knowledge to solve broad based Electrical Engineering related problems.
- **Environment and sustainability:** Apply Electrical engineering solutions for sustainable development practices in societal and environmental contexts.
- **Engineering tools:** Apply relevant Electrical technologies and tools with an understanding of the limitations.
- **The engineer and society:** Assess societal, health, safety, legal and cultural issues and the consequent responsibilities relevant to practice in the field of Electrical engineering.
- **Ethics:** Apply ethical principles for commitment to professional ethics, responsibilities and norms of the practice in the field of electrical engineering.
- **Communication:** Communicate effectively in oral and written form.

II Competency and Skills

The aim of this course is to help the student to attain the following industry identified competency through various teaching learning experiences:

- **Plan electrical installations with their cost estimates.**

III Relevant Course Outcome(s)

- Prepare tender, quotation and other related documents.

IV Practical Outcome

- Prepare tender documents, quotations, and bills for specified work.

V Minimum Theoretical Background

- Meaning and purpose of symbols used to represent electrical equipment in given electrical installation system.
- Application and need of electrical accessories and protective devices based on type of installation.
- IE rules pertaining to all type of electrical installation.
- Knowledge of estimation & costing as per current market rates.
- Comparative knowledge of various electrical product of different manufactures in relevance to technical, economical and service aspects.

VI Collection of Tender notification for electrical installation:

Note 1: The staff member required to suggest/ provide different tender notification to prepare quotation and bill.

Note 2: The staff member provide/ suggest preparing tender documents to carry out electrical installation work.

a. Prepare and Paste Tender notification to be published in newspaper.

(Sample of tender notice is given for reference)

MATERIAL MANAGEMENT CELL

Name of Company-----

Tender No. -----

Date:

BID / TENDER NOTICE

The Chief Engineer, Material Management Cell (MMC), on behalf of (Name of company of purchaser), hereby invites sealed bids from New Vendors for procurement of 11KV, 22 KV/0.433 KV, 10 KVA, 16 KVA & 25 KVA Three Phase Distribution Transformers with Energy Efficiency Level II as per IS 1180:2014 under HVDS. Entire bidding document is available online on [http://www.\(Company website\)](http://www.(Company website)) Tender/ e-tender as per date indicated below. Any changes in the Bid Schedule, corrigendum etc. shall also be notified via Company website. Prospective bidders are therefore requested to regularly check the website for any updates.

Tender No. -----

Estimated Tender Cost: Rs. 175.00 Crores

Tender Fee: Rs 25,000.00 + 18% GST

The bidder should submit non-refundable Bid Fee of Rs 25,000.00 + 18% GST paid through online payment only, prior to the dead line for submission of bids as per the procedure led by the (Company Name). Earnest Money Deposit: The bid must be accompanied with EMD @ 0.5% of estimated tender cost for an amount equal to Indian Rs. 87.00 Lakhs (Rs. Eighty Seven Lakhs only). The EMD shall be denominated in Indian Rupees only. The EMD can be paid online or should be submitted in original in the form of a Demand Draft or an Unconditional Bank Guarantee from any Nationalized / Scheduled Bank in favor of the (Company name) payable as mentioned in details in Tender Document (Section-I). The scanned copy of the online payment receipt / Demand Drafts / BG should be uploaded (in e tendering) and the Demand Drafts should be submitted to this office on or before submission date and time.

Calendar of Events Event	Date and Time
Begin Sale of Bid Document	28.05.2018
Date and time of submission of Bids	02.07.2018 up to 15.00 hrs
Date and time of Bid Opening	02.07.2018 at 16.00 hrs

Brief Scope of Work:

Procurement of 11 & 22 KV/0.433 KV, 10 kVA, 16 kVA, & 25 kVA, three phase Distribution Transformers with energy efficiency Level II as per IS 1180:2014 for the paid pending agriculture consumers under High Voltage Distribution System (HVDS) Scheme.

The quantity for procurement is as below.

11KV/0.433 KV, 10 KVA – 27,320 nos.

11KV/0.433 KV, 16 KVA – 8,900 Nos.

11KV/0.433 KV, 25 KVA – 760 Nos.

22KV/0.433 KV, 10 KVA – 1,680 Nos.

22KV/0.433 KV, 16 KVA – 100 Nos.

22KV/0.433 KV, 25 KVA – 40 Nos.

The actual quantity of the transformers that will be procured may vary depending upon the site requirement. The quantity mentioned as above against various capacities can undergo change. However, the minimum assured quantity for procurement shall be 50% of the total tendered quantity as mentioned above. The list of various destination sites / stores Centers of the Purchaser is enclosed as Annexure K.

Qualifying Requirements:

1. The bidder shall be an Original Equipment Manufacturer (OEM) of distribution transformer and possess valid BIS license.
2. The bidder should have in-house testing facilities for conducting acceptance tests in accordance with the procedures laid down in IS: 2026/1977 amended up to date.

THE CHIEF ENGINEER
(Name and Complete address of company)

- b. Prepare and paste quotation of suggested/ provided tender. (Sample BOQ of 2 BHK Flat is given for reference)

Item	Description	Unit	Qty	Rate (Kshs)	Amount (Kshs)
	2 Bedroom Unit - Type A				
	ELECTRICAL INSTALLATION WORKS				
	PVC/SWA/PVC Copper cables per meter				
A	(a) 25mm sq. 4 core	LM	35	200.00	7,000
B	(b) 95mm sq. 4 core	LM	35	300.00	10,500
	LIGHTING POINTS AND SWITCHES				
C	Lighting points wired in 3x1.5 mm ² PVC/SC cables drawn in 20 mm Ø concealed HG PVC conduits complete with all necessary accessories but excluding switches for:				
	i) One way switching	No.	6	1,400.00	8,400
	ii) Two Way with Intermediate Switching	No.	2	1,600.00	3,200
D	10A moulded ivory type switch plates as MK range or approved equivalent as follows:				
	i) One gang one way	No.	6	350.00	2,100
	ii) One gang two way	No.	2	400.00	800
	LIGHTING FITTINGS				
E	Lighting fittings as follows:				
	i) Single Light Bulb	No.	7	3,500.00	24,500
F	Socket outlet power points comprising wiring in 3 x 2.5mm ² PVC/SC copper cables drawn in 25mm Ø CONCEALED HG PVC conduits including all conduit accessories but excluding plates	No	5	2,500.00	12,500
G	13A moulded socket outlet plates as crabtree or approved equivalent as follows				
	i) Twin switched	No	2	550.00	1,100
H	15A Single switched socket outlet plates as crabtree or approved equivalent	No	2	650.00	1,300
I	50mmØ PVC HG conduits	LM	150	150.00	22,500
	METER BOARD				
J	100 Amps TPN MCCB as MEM or approved Equivalent	No.	1	6,500.00	6,500
	EARTHING				
K	Earthing of the meterboard and the installation comprising of the following 15mm x 1800mm earth rod as FURSE cat. No. RB 105	No	2	1200	2,400
	Total for Electrical Works				102,800
		H 8			

VII Resources Required

Sr. No.	Name of Resource	Suggested Plan	Quantity
1	Newspaper/ Online/ Electrical Contractor	Prepare tender documents, quotation and bills with consultation with electrical contractor	1

VIII Precautions to be followed:

1. Follow safety rules/ norms pertaining to all electrical installation.
2. Follow IE rules and regulations pertaining to all electrical installation.
3. Follow standard format while preparing tender.
4. Carry out market survey on the requirement of equipments mention in the tender while preparing quotation.

IX Procedure

1. Prepare tender document/ BID notice as suggested/ provided by staff member in standard format.
2. Specify all the terms and conditions in the tender notice as per the installation work.
3. Prepare quotation/BOQ for the prepared tender, mentioning technical specification with costing.

X Resources Used

Sr. No.	Name of Resource	Suggested Plan	Quantity
1			
2			

XI Actual Procedure Followed (use blank sheet if space is not sufficient)

.....

.....

.....

.....

.....

.....

XII Precautions Followed

.....

.....

.....

.....

.....

XIII Assumption and Calculation (Preparation of tender and quotation as per IE standards and market rates).

(Use blank sheet if space is not sufficient)

XIV Results (Factors considers while preparing tender notice and BOQ)

.....
.....
.....
.....
.....
.....
.....
.....
.....
.....

XV Interpretation and Assumption (Made while preparation of tender, notice & quotation).

.....
.....
.....
.....
.....
.....
.....
.....
.....
.....

XVI Conclusions (The extent of practical outcome achieved in preparation of tender and quotation)

.....
.....
.....
.....
.....
.....
.....
.....
.....
.....

XVII Practical Related Questions

Note: Below given are few sample questions for reference. Teachers must design more such questions so as to ensure the achievement of identified CO.

1. Difference between BID and Quotation.
2. State significance of BOQ (Bills of Quantities) in tendering.
3. Difference between BOQ and Quotation.
4. List and explain the different types of tender and quotation.

[Space for answers]

Dotted lines for writing answers.

XVIII References / Suggestions for Further Reading

1. <https://ask-the-electrician.com/wiringdiagrams.html>
2. <https://www.btechguru.com/courses--nptel--electrical-engineering-video-lecture--ee.ht..>
3. <https://www.electricaltechnology.org/2013/09/electrical-wiring.htm>
4. <https://www.howstuffworks.com/search.php?terms=electrical%20installatio>
5. <https://www.electrical4u.com/electrical-engineering-articles/utilities/>
6. <http://www.neca-neis.org/the-standards>
7. <http://www.metlabs.com/product-safety/2011-national-electrical-code-nec-updates-standard-for-the-safe-installation-of-electri>

XIX Assessment Scheme

Performance indicators	Weight-age
Marks: 25	
Collection of standard format of tender and quotation	20
Selection of work execution for tendering and quotation	10
Preparation of tender notice for the stated work	25
Preparation of quotation for the stated work	25
Answer to sample questions	10
Submission of report in time	10
Total	100 %

Names of Student Team Members

1.
2.
3.
4.

Marks Obtained			Dated signature of Teacher
Preparation & Making (15)	Understanding (10)	Total (25)	