

**Question Bank (G scheme)**

**Name of subject: MECHANICAL ENGINEERING DRAWING**

**Unit Test :I**

**Subject code: 17305**

**Course : ME**

**Semester: III**

**Q.1] Questions of 13 marks [set Any one question ]**

1. fig. below shows the front view, auxiliary view and incomplete side view of an object draw the given views and complete side view

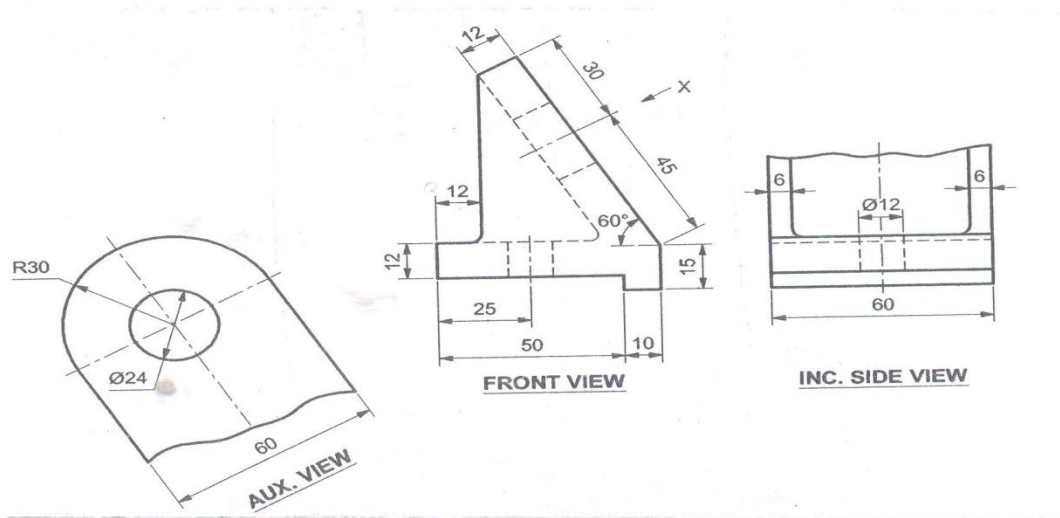

2. Fig. shows the top view , incomplete front view and partial auxiliary of a bracket redraw the top view and complete the front view

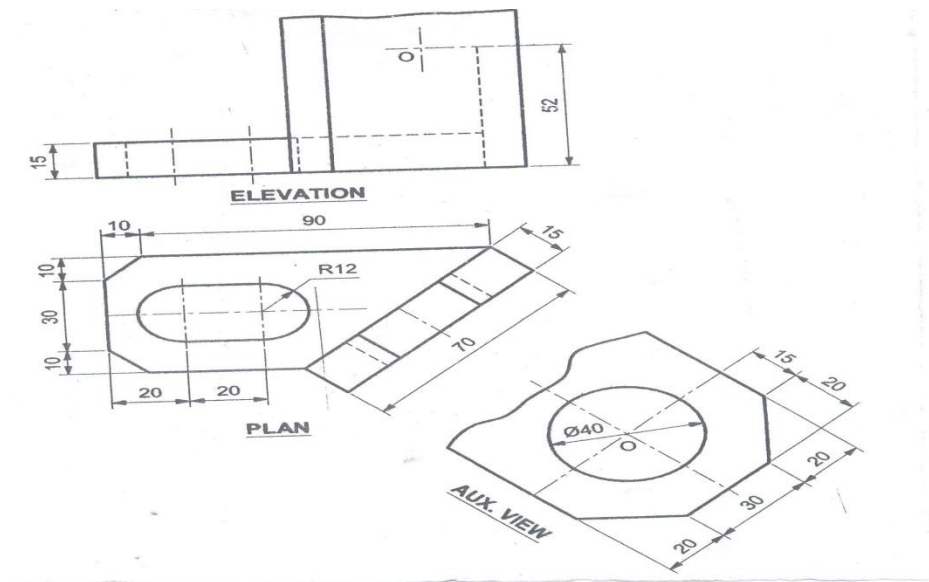

3. Front view, partial right hand side view and partial auxiliary view is shown in fig. below draw the given views and complete the R.H.S.V

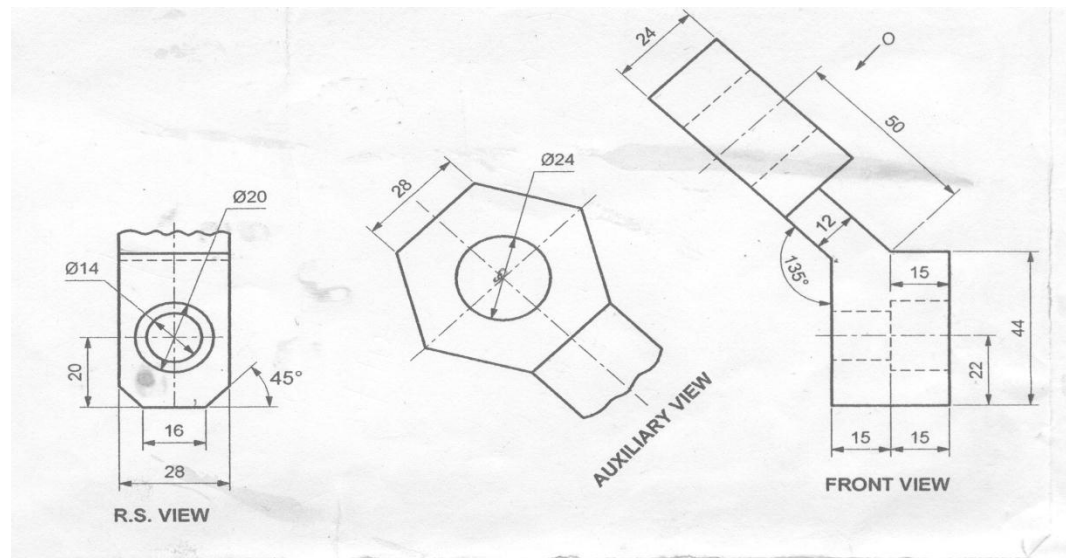

4. Fig. below shows front view, incomplete top view and auxiliary view of an object. Redraw the front view and complete the top view

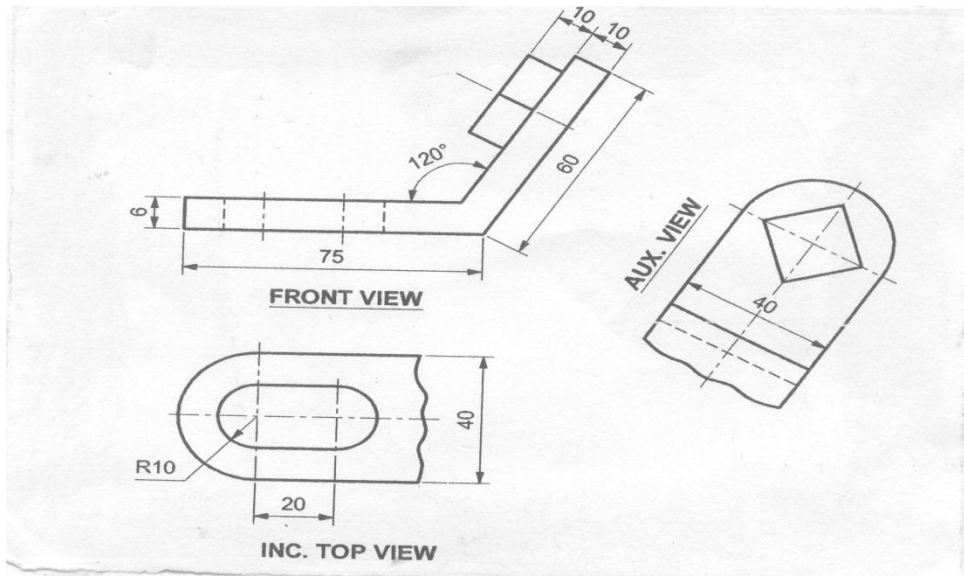

5. Fig. below shows a front view and side view of an object i.e. L.H.S.V. draw the given views and project an auxiliary top view, looking in the direction of X.

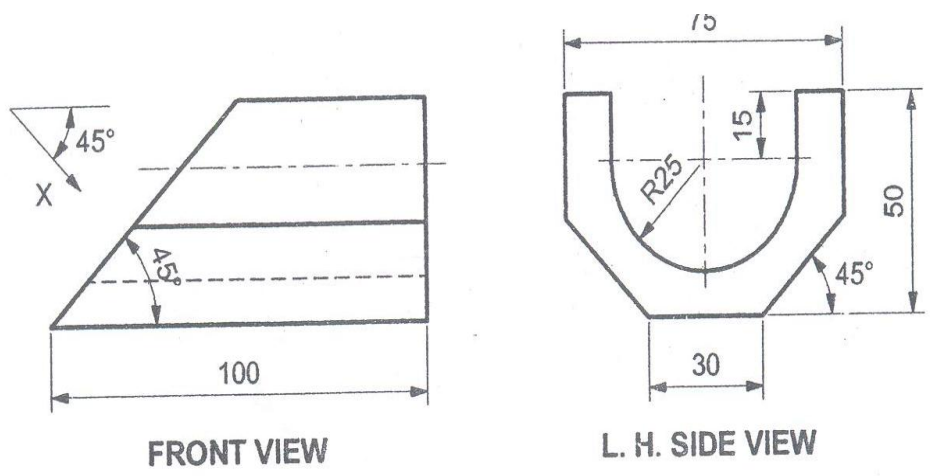

6. Fig. below shows the front view and side view of a block. Draw the given views and project an auxiliary view in the direction of arrow M.

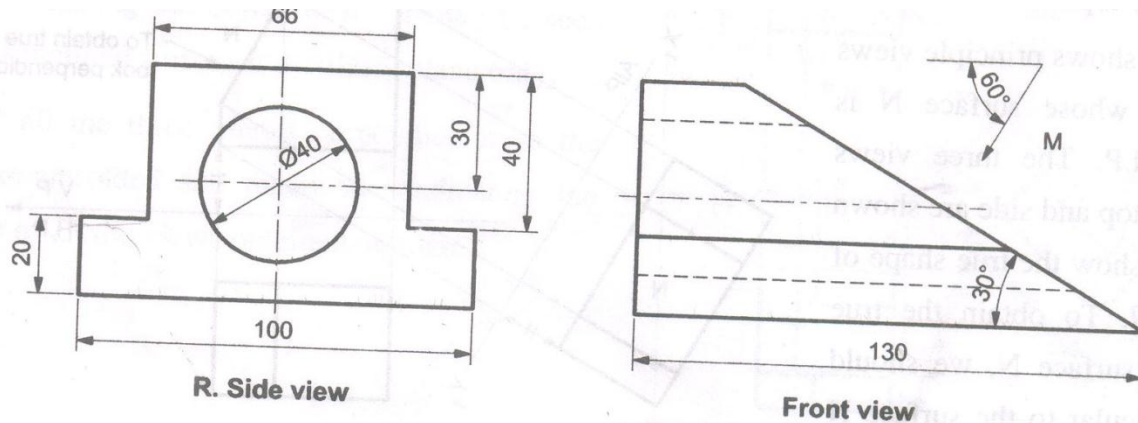

**Q.2] Questions of 6 marks [set three questions solve Any two]**

- 1] A vertical Square prism, base 50 mm side and height 90 mm is completely penetrated by a horizontal square prism, base 35mm side and axis length 90 mm so their axes are 6mm apart .the axis of the horizontal prism is parallel to the V.P while the faces of both prisms are equally inclined to the V.P draw the projection of the prisms showing lines of intersection
- 2] A vertical square prism (side of base 50 mm and axis length 100 mm) has its vertical faces equally inclined to the V.P. It is penetrated by another square prism (side of base 50mm and axis length 100mm) so that its axis is parallel to H.P. and V.P. and is 12mm in front of the axis of the vertical prism. The faces of penetrating prism are equally inclined to H.P. Draw the projections of the prism showing the lines of intersection.
- 3) A vertical cylinder of 75mm diameter and axis height 90mm is penetrated by another cylinder of 50mm diameter and axis height 100mm, the axis of which is parallel to both H.P. and V.P. The axes are 9mm apart. Draw the projections of two cylinders showing curves of intersection.
- 4) A vertical cylinder of 60mm diameter is penetrated by another cylinder of same size. The axis of both the cylinders is 90mm long. The axis of penetrating cylinder is parallel to both H.P. and V.P. and is 10mm away from the axis of the vertical cylinder. Draw the projections of two cylinders showing curves of intersection.
- 5) A vertical cylinder of 50mm diameter and height 60mm is penetrated by another cylinder of base diameter 40mm and axis length 90mm such that its axis is parallel to V.P. and bisects the axis of vertical cylinder. Draw the projections showing curves of intersection.
- 6) A vertical cylinder of 75mm diameter and 100mm axis length is resting on its base on H.P. it is penetrated by a horizontal square prism of 40mm side of base and 95mm axis length, the axis of which is parallel to V.P. and bisects the axis of cylinder while its faces are equally inclined to H.P. Draw the projections showing curves of intersection.

7) A circular cylinder with base diameter 60mm and axis length 60mm stands vertically on its base in H.P. A square prism with sides of base 25mm, axis length 80mm penetrates horizontally such that its axis is parallel to V.P. and 10mm away from the axis of vertical cylinder and is 30mm above the base of the cylinder. The faces of square prism are equally inclined with H.P. Draw the projections of solids with curves of intersection.

8). A vertical square prism base 60mm side and axis height 100mm has one face inclined at  $30^\circ$  to V.P. It is completely penetrated by a horizontal square prism of 45mm edge of base and 100mm long, faces of which are equally inclined to H.P., axis of both prisms are parallel to V.P. and bisects each other. Draw the projections of solids showing lines of intersection.